



# Silhouette v4.11

## **Administration User's Guide**

Note: This system is developed for use only by qualified medical professionals trained and experienced in its use. Do not use the system before reading and understanding this user's guide.

This document has been prepared by ARANZ Medical Limited for its customers. The content of this document is confidential. It may be reproduced only with written permission from ARANZ Medical Limited. Specifications contained herein are subject to change, and these changes will be reported in subsequent revisions or editions. The device described in this document cannot substitute for the knowledge, skill and experience of the competent medical personnel who are its intended users. Its use as such a substitute is prohibited.

**Copyright © 2018-2021 ARANZ Medical Limited**

All rights reserved. Unauthorized use, reproduction, or disclosure is prohibited. Patents pending. No patent liability is assumed with respect to the use of the information contained herein. While every precaution has been taken in the preparation of this user's guide, ARANZ Medical assumes no responsibility for errors or omissions. Neither is any liability assumed for damages resulting from use of the information contained herein.



ARANZ Medical Limited

Tel +64-3-374 6120, Fax +64-3-374 6130

Postal Address:

ARANZ Medical

PO Box 3894

Christchurch 8140

New Zealand

Delivery Address:

ARANZ Medical

47 Hereford Street

Christchurch 8013

New Zealand

CE Authorised Representative

mdiEUROPA

Phone +49 (0)511 39089530

werner.sander@mdi-europa.com

Langenhagener Str. 71

30855 Langenhagen

FDA Authorised Representative

MDI Consultants

Phone +1 (516) 482 9001

alan@mdiconsultants.com

TGA Sponsor #55050

Brandwood CKC Pty Limited

Phone +61 (0) 2 9906 2984

help@brandwoodckc.com

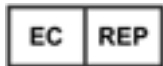

ARANZ Medical Limited documentation often refers to hardware or software products by their trade names. In most, if not all, cases these designations are claimed as trademarks or registered trademarks of their respective companies. The trade names are used here for identification purposes only.

Document Number: 2018-00263 Rev10.0

# Contents

---

<b>Introduction to Silhouette</b> .....	<b>1</b>
Document Conventions .....	1
Topics .....	2
<b>System Description</b> .....	<b>3</b>
Wound Care .....	3
Wound Research .....	3
System Components .....	4
System Security Features .....	5
Silhouette User Authentication .....	5
Silhouette User Session Management .....	6
SilhouetteCentral Data Security .....	7
SilhouetteConnect Data Security .....	8
SilhouetteStar 2 Data Security .....	8
SilhouetteLite and SilhouetteLite+ Data Security .....	9
Licensed Features .....	10
SilhouetteCentral & SilhouetteTokenService Licensed Features .....	10
SilhouetteConnect Licensed Features .....	10
<b>Using Silhouette</b> .....	<b>12</b>
Logging In to Silhouette .....	13
License Warnings .....	13
Changing Passwords .....	13
Recovering Forgotten Password .....	14
Navigating in Silhouette .....	16
Application Menu .....	16
Identifying Patients .....	18
Searching and Selecting Patients .....	18
Patient Banner and Sidebar .....	19
Capturing Wound Images .....	21
Connecting a SilhouetteStar to SilhouetteConnect using USB .....	21
Connecting a SilhouetteStar 2 to SilhouetteCentral using Wi-Fi .....	21
Using the SilhouetteStar to capture images .....	22
Disconnecting the SilhouetteStar .....	22
Logging Out from Silhouette .....	23
<b>Silhouette Concepts and Operation</b> .....	<b>24</b>
Clinical Groups, Clinical Users, and Units in Silhouette .....	24
Provisioning Units and Groups .....	25
Provisioning Users .....	25

---

Importing Groups, Users and Units .....	26
Home Users in Silhouette .....	27
Assessments and Patient Notes .....	28
Assessments .....	28
Patient Notes .....	28
Wounds .....	29
Orders and Encounters .....	30
System Events .....	31
Assessment Email .....	32
Sending Email .....	32
Email System Configuration .....	32
Email System Auditing .....	33
Silhouette Integration .....	34
Silhouette Inbound Integration .....	35
Silhouette Outbound Integration .....	37
<b>Clinical Data Export .....</b>	<b>39</b>
Creating a New Data Export .....	39
Clinical Data Export for Multiple Patients .....	40
Clinical Data Export for a Single Patient .....	42
Downloading a Data Export .....	43
<b>Silhouette Administration .....</b>	<b>45</b>
Users .....	46
Creating a Silhouette Local Clinical User .....	47
Viewing and Editing a User .....	47
Groups .....	49
Creating a Group .....	50
Group Details .....	50
Group and Unit Relationship .....	50
Group Permissions .....	51
Editing a Group .....	56
Email Lists .....	57
Creating an Email List .....	58
Editing an Email List .....	60
Assessments .....	62
Editing an Assessment Type .....	64
Creating an Assessment Action .....	65
Editing an Assessment Action .....	66
Assessment Action Details .....	67
Trigger Details .....	68

---

Action: Send Email Details .....	70
Action: Send Integration Event Details .....	71
Patient Notes .....	72
Editing Patient Notes .....	73
Unit Administration .....	74
Editing a Unit .....	75
SilhouetteStar 2 .....	76
SilhouetteStar 2 DHCP Configuration .....	76
Checking the SilhouetteStar 2 DHCP Configuration .....	78
Network Configurations and Wireless Camera Tools .....	79
Creating a Network Configuration .....	81
Editing a Network Configuration .....	81
Retrieving SilhouetteStar 2 Device Logs .....	82
License .....	83
Licensing Silhouette .....	83
Email Configuration .....	84
SMTP Configuration .....	84
Welcome Email .....	85
Email System Statistics .....	86
Anatomical Sites .....	88
Anatomical Site Codes .....	89
Editing Anatomical Site Codes .....	90
Silhouette Configuration .....	91
Automatic Boundary Detection .....	91
Outbound Integration .....	92
Inbound Integration .....	93
<b>Appendices .....</b>	<b>94</b>
Appendix A: Getting Support .....	95
Appendix B: Anatomical Site Hierarchy .....	96
Head & Neck .....	96
Torso .....	98
Pelvis .....	100
Upper Extremity .....	101
Lower Extremity .....	103
Appendix C: Wound State Definitions .....	106
Selectable Wound States .....	106
Wound State Notes .....	106
Wound State Notes: Open .....	106
Wound State Notes: Healed .....	106

---

Wound State Notes: Released from Follow-up .....	107
Wound State Notes: Amputated .....	107
Appendix D: Notes Definitions .....	108
Patient admission .....	108
Details .....	108
Physicians .....	108
Patient Details .....	109
Details .....	109
Address .....	110
Contact .....	111
Patient discharge .....	111
Details .....	111
Assessment of lower limb function .....	112
Right .....	112
Ambulation .....	115
Left .....	115
Comments .....	118
Visit Assessment .....	118
Vital signs .....	118
Related Pain (Non-Wound) .....	119
Edema .....	120
Factors Affecting Healing .....	121
Wound Assessment .....	123
Images .....	123
Details .....	124
Wound Pain .....	126
Comments .....	128
Investigation History .....	129
Investigation History .....	129
Medical History .....	130
Medical History .....	130
Medication .....	132
Medication .....	132
Sensitivities .....	132
Appendix E: Order and Encounter Notes Definitions .....	133
Order Notes .....	133
Encounter Notes .....	133
Appendix F: Clinical Data Export Format .....	135
ISO 8601 Date and Time Format .....	135

---

Silhouette Identifiers .....	135
Observation Information .....	136
Wound Information .....	137
Patient Notes .....	137
Wound State Notes .....	139
Assessment Notes .....	139
Appendix G: Regular Expressions .....	153
Patient Identifier Examples for Silhouette .....	153
Example A .....	153
Example B .....	153
Example C .....	153
Example D .....	153
Other examples .....	154
Things to Note .....	155
Appendix H: Conditional Expression Syntax .....	156
Appendix I: Template Macros .....	158
Dates .....	158
Assessment Integration Filename Templates .....	158
Appendix J: Email Templates .....	161
Silhouette Assessment Emails .....	161
Silhouette Welcome Emails .....	161

# Introduction to Silhouette

This Administration User's Guide is intended for Silhouette administrators and is focused on the system administration features.

Other user guides available are:

- The Silhouette Installation and Configuration Guide, which covers the installation and initial configuration of SilhouetteCentral and SilhouetteConnect.
- The Silhouette Clinical User's Guide, which covers the clinical features for clinical users.

This guide is applicable to the following versions of the Silhouette components:

- SilhouetteCentral version 4.11.
- SilhouetteConnect version 4.11.
- SilhouetteStar 2 software version 1.9.
- SilhouetteLite version 1.9.
- SilhouetteLite+ version 1.9.

## Document Conventions

Throughout this user's guide, screen, menu, and field names in Silhouette are displayed in a **bold font**. A series of actions are referred to as follows:

**Admin > Organization > Settings**

which means to select the **Settings** option in the **Organization** menu in the Silhouette Admin section.

The screens your web browser displays may differ slightly from the screen captures shown in this document. However, such differences are minor and do not affect the performance of Silhouette.

Throughout this user's guide, references to Silhouette mean both the SilhouetteConnect Microsoft Windows application and the SilhouetteCentral web application. Where a feature or function is only applicable to one of the Silhouette applications then that application is specifically stated.



## Topics

This user's guide is divided into the following high level topics:



[System Description](#)



[Using Silhouette](#)



[Silhouette Concepts and Operation](#)



[Clinical Data Export](#)



[Silhouette Administration](#)



[Appendices](#)

# System Description

## Wound Care

Silhouette is used in clinical practice by some of the world's largest healthcare providers, including the department of Veteran's Affairs in the US, the NHS in the UK, and many other clinics and hospitals in more than 30 countries. For clinical practice, Silhouette delivers:

- Reliable, accurate and timely wound documentation
- An easy to use solution for staff
- A non-invasive solution for patients
- Reduced commercial and litigation risk
- Improved patient satisfaction
- Fewer hospital admissions and visits
- Shorter hospital stays
- A reduction in the total cost of patient care.

## Wound Research

Silhouette's ability to reliably capture, measure, and manage wound data has been proven in more than 70 clinical trials globally. For clinical research, Silhouette delivers:

- High quality data to support study endpoints
- Highly accurate, reliable, and repeatable measurements (inter- and intra-operability)
- Reliable data collection for pre-clinical through phase IV, post-marketing surveillance, and observational trials
- A scalable solution for studies from one site to 250+ investigator sites
- Immediate access to images, data, and reports for sponsors, CROs, adjudicators, and sites
- One-click PDF wound assessment reports can be used as source documentation
- Data exports on demand (future release)
- An easy to use solution for clinical sites.

More details on the system are available in the following topics:

- [System Components](#)
- [System Security Features](#)
- [Licensed Features](#)

## System Components

**Silhouette** is a computerized wound imaging, analysis, and documentation system.

**SilhouetteCentral** enables users to review, report, securely share and analyze the wound data collected by SilhouetteConnect, SilhouetteLite+ and SilhouetteLite applications. SilhouetteCentral is accessed via a web-based application and can collect wound data directly with a SilhouetteStar 2 device.

SilhouetteCentral is divided into four parts:

- Clinical - Provides access to the patient medical data stored in the Silhouette database for reviewing, editing, and updating. Reports, images, and wound measurement data can also be exported for further processing and importing into other applications.
- Administration - Provides facilities to manage units, groups, patients, and system users. SilhouetteCentral can also be used to configure and customize the Silhouette system.
- Integration Interfaces - SilhouetteCentral allows integration of assessment data with other health IT systems using the Silhouette Integration Interface.
- SilhouetteTokenService - Provides centralized user authentication services to the Silhouette suite of products. The token service can also support single sign-on (SSO) for enterprise users using SAML2.0 protocols, typically by integrating with an enterprise's ADFS provider.



In this version of SilhouetteCentral there is limited configurability available via the main web app. Contact ARANZ Medical Support if configuration changes need to be made.

**SilhouetteConnect** is the software installed on a Microsoft Windows tablet, laptop or desktop computer.

SilhouetteStar devices connect via USB to a computer running SilhouetteConnect. SilhouetteConnect enables wound assessments to be performed without connection to a network, and the data is synchronized with SilhouetteCentral when a network connection is available.

SilhouetteConnect can be used in two modes of operation:

- Standalone mode provides the power of Silhouette on a single PC. Data is collected and stored on the PC. PDF reports can be generated to share the results.
- Synchronized mode provides offline and wired SilhouetteStar device support for SilhouetteCentral systems. Data collected by SilhouetteConnect can be uploaded to SilhouetteCentral and data stored in SilhouetteCentral can be downloaded and used offline in SilhouetteConnect. In synchronized mode the system is mostly administered in SilhouetteCentral and the appropriate settings are downloaded during the synchronization process.



In this version of SilhouetteConnect there is limited configurability available via the main web app. Contact ARANZ Medical Support if configuration changes need to be made.

**SilhouetteStar 1** is a device that captures wound images and non-contact 3D measurements of wounds at the point of care. SilhouetteStar 1 operates over a USB cable connected to a computer running SilhouetteConnect software.

**SilhouetteStar 2** is a device that captures wound images and non-contact 3D measurements of wounds at the point of care. The images and data captured with SilhouetteStar 2 are uploaded to SilhouetteCentral over a secure Wi-Fi network or to SilhouetteConnect over a USB cable.

SilhouetteStar 2 has software running on it. The software version for SilhouetteStar 2 is typically compatible with a limited range of SilhouetteCentral and SilhouetteConnect software versions. The software on a SilhouetteStar 2 upgrades or downgrades when it is connected to Silhouette to ensure it is compatible.

SilhouetteStar 2 is an IP network device. In wired mode, the device uses a IP network that is local to the computer running SilhouetteConnect. The USB device appears as a network interface in Microsoft Windows using the RNDIS protocol. In wireless mode, the device communicates over the Wi-Fi IP network directly to SilhouetteCentral.

**SilhouetteLite+** is comprised of an application and a range finding sensor for Apple® iPhone®, iPod® touch and iPad® devices. SilhouetteLite+ enables users to take wound images, obtain non-contact 2D measurements, and record patient notes on their mobile device. The data collected at the patient's bedside is synchronized with SilhouetteCentral over a secure connection when available.

**SilhouetteLite** is an application designed for Apple® iPhone®, iPod® touch and iPad® devices. SilhouetteLite is a simplified application that enables users to add patients, wound images and simple notes (without measurements) to SilhouetteCentral. The data collected at the patient's bedside is synchronized with SilhouetteCentral over a secure network connection when available.

## System Security Features

### Silhouette User Authentication

There are very few pages or actions available to unauthenticated users within Silhouette. All access to patient data and personal information requires the user to be authenticated.

Unauthenticated pages include:

- The unauthenticated landing page.
- The login page.
- The download SilhouetteConnect client page.

When using SilhouetteCentral as part of your Silhouette deployment, all system components use the SilhouetteTokenService provided by SilhouetteCentral to authenticate users. The only component in the system which prompts a User for their User Name and Password information to authenticate them is the SilhouetteTokenService. Once that component authenticates a user it issues limited lifetime security tokens to the client application, allowing the client applications to gain access to the system resources.

The SilhouetteTokenService can optionally authenticate Silhouette local users, Silhouette system clients, and can also use external authentication providers (such as ADFS) to authenticate users through the SAML2.0 single sign on (SSO) protocol. Regardless of provider of user authentication, a user record is created within Silhouette to enable:

- Display of the User's name as they use the application.
- Recording their actions relating to data for audit purposes.
- Optional sending of emails (welcome emails and assessment emails).
- The assignment of Silhouette permissions to the user.

## 6 • Silhouette User Session Management

Silhouette local user records are configured in the Silhouette database and have a User Name and a Password. The management of Silhouette Local Users is performed by administrators from within the Silhouette application.

Silhouette system clients are configured in the Silhouette database and have a client identifier and a client secret. The only system client supported by default is the integration client used for accessing the Silhouette Integration Interface. The integration secret is configured by administrators from within the Silhouette application.

User who are authenticated by external authentication providers have user records provisioned in the Silhouette database when they log in, commonly known as Just-In-Time (JIT) Provisioning. These user records are managed in an external directory (e.g. Active Directory) and are updated in Silhouette only when that user logs in to Silhouette again.

- User details recorded in Silhouette are updated when the user logs in.
- The user assignment to Silhouette permissions is through dynamic mapping of external group membership to Silhouette groups. Their group mapping is checked each time they login and their Silhouette assignment is adjusted according.
- Silhouette expires unused external provider user records after a set period (nominally 90 days) of inactivity. This expiration is so that users that are disabled in the remote directory will not show as active forever in Silhouette, as a user record is only updated when a user logs in. If an infrequent but active user gets their record expired it automatically gets provisioned again the next time they login.

Due to the different nature of each of the Silhouette client applications, the user login experience varies slightly between them.

- The SilhouetteCentral web application is perhaps the simplest to understand as the user is seamlessly redirected to the SilhouetteTokenService to be authenticated before gaining access to the web app.
- The non-web applications (SilhouetteConnect, SilhouetteLite and SilhouetteLite+) open the default web browser to login using the SilhouetteTokenService web page or SSO login page. The application waits on the authentication to be completed in the web browser before the user gains further access to the application and data.

The client applications do not handle the users credentials, reducing the opportunity for them to be compromised.

### SilhouetteConnect Standalone Mode



When operating in Standalone mode, SilhouetteConnect uses the Microsoft Windows operating system user as the user and trusts the operating system authentication. SilhouetteConnect provisions a user record for the Windows user so that application permissions can be applied and user actions tracked for audit purposes, but does prompt the user for their login credentials.

## Silhouette User Session Management

A user session duration within Silhouette varies based on the client application in use.

A SilhouetteCentral user session begins when the user logs in to the SilhouetteCentral web application and ends on any of the following events:

- The user closes the web browser.
- The user selects **Logout** from the SilhouetteCentral application menu.
- The SilhouetteCentral web application times the user session out due to inactivity (optional configuration).



The SilhouetteCentral web application inactivity timeout relies on the web application being left open. If the user leaves the web application without closing the browser then the inactivity timeout will not timeout the user session.

A SilhouetteConnect user session begins when the user logs in to the SilhouetteConnect application and ends based on the following events:

- The user selects **Logout** from the SilhouetteConnect application menu.
- The Sync URL is changed in the application.
- The SilhouetteConnect Maximum Offline Session Time has been exceeded (checked when the user opens or unhides the application).



When enabled for offline sessions, the SilhouetteConnect session is maintained when the user closes the application without logging off.

The SilhouetteConnect user with an active offline session may be asked to re-authenticate to perform a sync with SilhouetteCentral if the limited lifetime security token expires.

A SilhouetteLite or SilhouetteLite+ user session begins when the user logs in to the app and ends based on the following events:

- The user selects **Logout** from the navigation bar in the app.
- The user changes the **SilhouetteCentral Sync URL** in the app settings.
- Another user selects Change User or attempts to login when prompted due to a failure to complete a sync with the existing session information.



The SilhouetteLite and SilhouetteLite+ user sessions continue until they log out from the app but they may be asked to re-authenticate if they do not use the app and the limited lifetime security token expires.

Authenticating with any of the client applications always initiates a SilhouetteTokenService user session in the web browser, which ends when they close the web browser or when a SilhouetteCentral user session is terminated. A SilhouetteTokenService user session being left active in the web browser is evident when the user selects **Login** in a client application but are not requested for their credentials. An example is described in the sequence:

1. A SilhouetteConnect user selects **Login**, causing their web browser to open with the login page.
2. The user completes the login process but leaves the web browser open.
3. The user selects **Logout** in SilhouetteConnect, causing their SilhouetteConnect user session to be terminated.
4. The user selects **Login** in SilhouetteConnect, causing their web browser to open but no login page is shown and they are redirected back to SilhouetteConnect and logged in based on their still active SilhouetteTokenService session.

## SilhouetteCentral Data Security

Patient demographic information and associated measurement data is stored in a Microsoft SQL Server database. The database uses standard SQL Server authentication mechanisms. SQL Server includes various mechanisms to

## 8 • SilhouetteConnect Data Security

encrypt both the database and the connection between the database and SilhouetteCentral.

SilhouetteCentral also stores some data in files directly on the file system. It is recommended to configure the host server to use drive encryption to provide encryption of data at rest. The data stored in files includes the following:

- Images are stored in a compressed, proprietary format with anonymized file names.
- Assessment reports requested by a SilhouetteCentral user are created in PDF format and are stored temporarily while being downloaded by the end user.
- Assessment reports generated by the system for Email attachments are stored in accordance to the Email purging configuration (default = 35 days).
- Data exports (csv files) are stored for a number of days (default = 3 days) to be made available for download by the user who created them.
- SilhouetteConnect databases that are uploaded as part of the Sync process are kept on the silhouette file system for a number of days (default = 10 days) to prevent data loss and allow any data conflict problems to be resolved.

Both the databases and associated files can be stored on the same or different machines depending on the installation criteria.

### SilhouetteConnect Data Security

SilhouetteConnect stores data offline from SilhouetteCentral on a local disk of a PC. The database, images and PDF reports are stored unencrypted on the file system. It is recommended to deploy SilhouetteConnect on systems with BitLocker security (or similar) turned on to keep the patient data secure.

To help protect data in use, SilhouetteConnect provides an application timeout that hides data displayed on the screen. This does not require re-authentication to show the data again. Use the operating system session lock features to provide secure session lock for Silhouette, protecting the application and the stored data.

If synchronizing SilhouetteConnect to a SilhouetteCentral:

- Use the HTTPS protocol to secure the communications with the TLS protocol.
- There are system wide settings for how long SilhouetteConnect will operate offline without contacting SilhouetteCentral to authorize the user.

### SilhouetteStar 2 Data Security

SilhouetteStar 2 captures images of wounds, creates a 3D model for measurements and uploads the images to SilhouetteCentral over a Wi-Fi network or a USB wired connection. The images are uploaded and removed from the device almost immediately. If there is a network issue which prevents the immediate uploading of images they are kept on the device only until it turns off.

SilhouetteCentral must be configured to use HTTPS to keep the data secure over the Wi-Fi network.

SilhouetteStar 2 displays the patient name, patient id and date of birth of the patient being assessed by a user via the SilhouetteCentral web interface. Once the clinician closes the web browser or navigates away from the patient, the patient information is removed from the screen and from the devices memory. If there is a communications issue the patient information will remain on the device screen until it enters sleep mode or successfully reconnects to the SilhouetteCentral, allowing images to be captured for that patient semi-offline.

All patient data or images are stored in volatile memory so it is lost if the device turns off.

## SilhouetteLite and SilhouetteLite+ Data Security

The SilhouetteLite and SilhouetteLite+ apps support offline operation. A list of patients from Silhouette is stored on the mobile device as well as any assessments waiting to be uploaded. Once assessment data is uploaded to SilhouetteCentral it is removed from the mobile device.

Apple devices offer FIPS 140-2 validated encryption for data stored on the device. The Apple [iOS Security Guide](#) provides a description of how file security works on the device and how it works with iTunes syncs and backups. To ensure the data displayed and stored on the device is safe the following configuration recommendations are made:

- Use Passcode security on the device to enable data file encryption and to protect the device from unauthorized users accessing it.
- Use device owner identification (passcode or biometric authentication) on the device to provide an additional authentication check when launching the SilhouetteLite or SilhouetteLite+ apps in offline mode. The use of device owner identification for access to the apps is enabled by default in SilhouetteCentral, but disabled if required.
- Use screen lock as a session lock to prevent users accidentally leaving sensitive data available.
- Use the Apple Configurator 2 app to supervise devices, in particular:
  - Disable screenshot capabilities, and
  - Disable the Allow pairing to computers for content sync setting or enable the Force encrypted backups feature.



## Licensed Features

### SilhouetteCentral & SilhouetteTokenService Licensed Features

A number of optional features can be added to a SilhouetteCentral license.

Feature Name	Feature Description
Assessment Email Actions	The Assessment Email Actions feature allows SilhouetteCentral to be configured to send email alerts on assessment creation and / or updates. <a href="#">See Assessment Email</a> for more details. Available for SilhouetteCentral v4.3 and above.
Clinical Data Export	The Clinical Data Export feature for SilhouetteCentral enables assessment data to be exported into comma separated values (csv) format. Available for SilhouetteCentral v4.4 and above.
Silhouette Integration Interface	The Silhouette Integration Interface feature allows SilhouetteCentral to be integrated to an external system through the third party NextGen Connect (Mirth Connect) open source integration engine. Available for SilhouetteCentral v4.7 and above.
Home User Access	The Home User Access feature allows home user groups and accounts to be created within Silhouette. A home user can login to SilhouetteCentral, review their record and submit basic images and data captured on their own device. Available for SilhouetteCentral v4.10 and above.
SSO Integration	The SSO Integration feature allows Single-Sign-On (SSO) integration with external identity providers (e.g. ADFS) through the SAML 2.0 protocol. A user with an appropriately configured account on the external identity provider will be able to access Silhouette without having a separate Silhouette local user account. Available for SilhouetteTokenService v4.11 and above.

### SilhouetteConnect Licensed Features

A number of optional features can be added to a SilhouetteConnect license.

Feature Name	Feature Description
Clinical Data Export	<p>The Clinical Data Export feature for SilhouetteConnect enables assessment data to be exported into comma separated values (csv) format from SilhouetteConnect when operating in standalone mode (not synchronizing to SilhouetteCentral). In synchronizing systems, data export will only be available from SilhouetteCentral.</p> <p>Available for SilhouetteConnect v4.4 and above when operating in standalone mode.</p>

## Using Silhouette

This section describes the basics of using with Silhouette. It is divided into the following topics:



[Logging In to Silhouette](#)



[Navigating in Silhouette](#)



[Logging Out from Silhouette](#)

## Logging In to Silhouette

To log in to SilhouetteCentral, navigate to the website address of your SilhouetteCentral instance using a Web Browser.

To log in to SilhouetteConnect, start the SilhouetteConnect application on your computer.

The log on screen will appear. Enter the **User Name** and **Password** supplied to you. Select **Login**.



It is important to log on using the **User Name** and **Password** assigned to you. Silhouette records the names of users viewing, creating, and modifying patient records, and using the correct user name ensures accurate auditing.

While logging on to Silhouette you may occasionally be prompted to change your password if a system administrator has made use of the password expiry features. In this case you will need to pick a new password that meets the password complexity requirements and enter it before Silhouette will allow you to log on.

When logging in to SilhouetteCentral, web browsers may prompt you to save a **User Name** and **Password**. If using a shared computer, it is recommended that you do not permit the browser to save your login detail for SilhouetteCentral. Doing so, means that anyone using your computer can log on, access and potentially modify patient medical records that will be recorded as having been completed by you.

## License Warnings

License warnings are displayed in both SilhouetteConnect and SilhouetteCentral if the license is nearing expiry. The warning is shown in a banner near the top of the screen once any user is logged in.



- A** Select the **Check for Update** link to query the ARANZ Medical licensing server for an update. The **Check for Update** function can also be accessed through the Admin pages.
- B** Select the **x** button to dismiss the warning banner. The banner will be dismissed until the user logs in again.

## Changing Passwords

For users with permission to manage Users and Groups, your own and others passwords are managed via the [Users](#) screen.

Note that user names and passwords are used across the Silhouette Product Suite, so you will also need to use the new password when logging in to SilhouetteCentral, SilhouetteConnect, SilhouetteLite or SilhouetteLite+.

## 14 • Recovering Forgotten Password

For users without permissions to manage Users and Groups to change their Silhouette password:

1. Navigate to the **Admin > Profile** screen.
2. Select the **Change Password** button.
3. Enter your existing password in the **Current Password** box.
4. Enter your new password in both the **New Password** and **Confirm Password** boxes.
5. Select the **Save** button to update the system with your new password.

When SilhouetteConnect is operating in Synchronized mode, in addition to changing their password in SilhouetteCentral, as above, all users can change their password by accessing **Admin > Profile** in SilhouetteConnect. A synchronization must be performed before the password change is applied across the system. During synchronization SilhouetteConnect needs to ask for the user's old Silhouette password (which SilhouetteCentral still has) to successfully complete. If the old password can't be remembered the password can be reset via SilhouetteCentral, before the sync can proceed.

Logging in to an offline SilhouetteConnect after a password has been changed in SilhouetteCentral requires the users original password until a synchronization is completed. When SilhouetteConnect is online, it allows the new password to be used.

### Recovering Forgotten Password

If you have forgotten your password, use the "**Forgot your Password?**" link on the SilhouetteCentral log in screen. This link is only available in SilhouetteCentral, not SilhouetteConnect. If you do not see this link, your administrator may have chosen to disable this feature, in which case contact your system administrator for further advice on how to regain access to your account.



Once the "Forgot your password?" link is selected you will be prompted to enter your email address. You should enter the email address that is associated with your Silhouette user name.

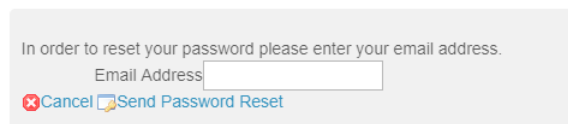

You will get a message that an email with instructions to reset your password has been sent to the email address you specified.

**Password reset request**

Information on how to complete your password reset request has been sent to your email address.

Please check the email for instructions on how to complete the password reset.

When you check your email account and receive the email sent by Silhouette you will find a link that can be used to reset your password. Selecting the link will load the Silhouette website and prompt you to enter a new password.

Please enter the new password for 'test'.

The password must match the following criteria:

- A minimum of 3 characters.
- A maximum of 20 characters.

**New Password \***

**Confirm Password \***

You will receive a confirmation that your password has been changed and you can now proceed to log on with the new password.

**Password Reset**

Your password has been reset, please proceed to log on with your new password.

If you receive a password reset request email and do not remember requesting it, an additional link in the email may (depending upon system configuration) be provided that allows you to cancel the password reset request so any other person who manages to view the email can not reset your password.

Password reset request canceled. The link can no longer be used to reset your password.

User Name

Password

[Forgot your password?](#)

In some circumstances you may get a password reset email that indicates your user account is not able to have its password reset via email. In this scenario contact your system administrator for further instructions on how to reset your password.

## Navigating in Silhouette

The basics of navigating within Silhouette are described in the following topics:

- [Application Menu](#)
- [Identifying Patients](#)
- [Searching and Selecting Patients](#)
- [Patient Banner and Sidebar](#)
- [Capturing Wound Images](#)

### Application Menu

Once you have logged in to Silhouette, your name is shown in the top right-hand corner. Select your name to show the Application Menu. The options available in the application menu depend on the options available in your application and on your permissions.

Application Menu for SilhouetteCentral and SilhouetteConnect in Standalone mode.

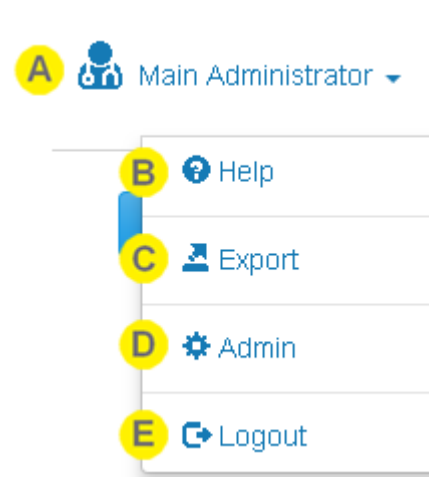

Application Menu for SilhouetteConnect in Synchronized mode.

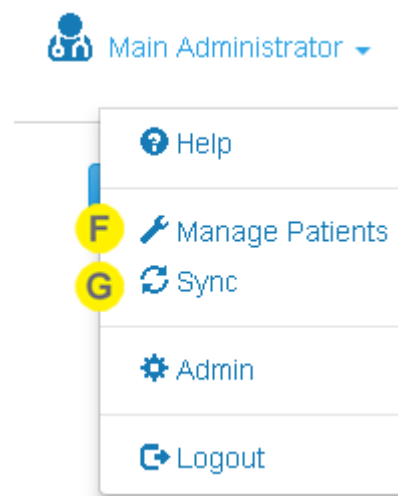

- A** Select your name in the top right of the application to show the Application Menu.
- B** **Help**  
Contains links to the User Guides to help you use Silhouette. It also contains the links to legal and licensing information for Silhouette.
- C** **Data Export**  
Opens the Data Export screen, where clinical data exports can be generated and downloaded.  
This menu item is only shown if the current user has the **Can Export Data** permission.  
This menu item is not available in SilhouetteConnect if it running in Synchronized mode.
- D** **Admin**  
Change your account settings such as your name, email address and password.  
Also, if your account has the correct permissions, then you can administer settings for the application. [See Silhouette Administration](#).
- E** **Logout**  
Log out of SilhouetteCentral. [See Logging Out from Silhouette](#).
- F** **Manage Patients**  
Opens the Manage Patients screen on SilhouetteConnect, allowing the selection of patients to download to this instance of SilhouetteConnect.  
This menu item is only shown in SilhouetteConnect if it is running in Synchronized mode and if the current user has the **Can Manage Patients** permission.
- G** **Sync**  
Initiates a Sync to SilhouetteCentral.  
This menu item is only shown in SilhouetteConnect if it is running in Synchronized mode and if the current user has the **Can Synchronize** permission.



## Identifying Patients

Silhouette uses three (3) pieces of information to positively identify patients. By default, this information is setup for clinical practice environments:

- Patient name (first name + last name)
- Patient ID
- Patient Date of Birth

These bits of information are displayed throughout the system to help positive identification of the patient being imaged.

Silhouette requires that every patient in the system has an ID. The patients name and date of birth can be made optional for clinical research focused deployments.

Contact ARANZ Medical support to make changes to the patient identifiers.

## Searching and Selecting Patients

In some Silhouette screens, you can search for patients by their first name, middle name, last name, or Patient ID.

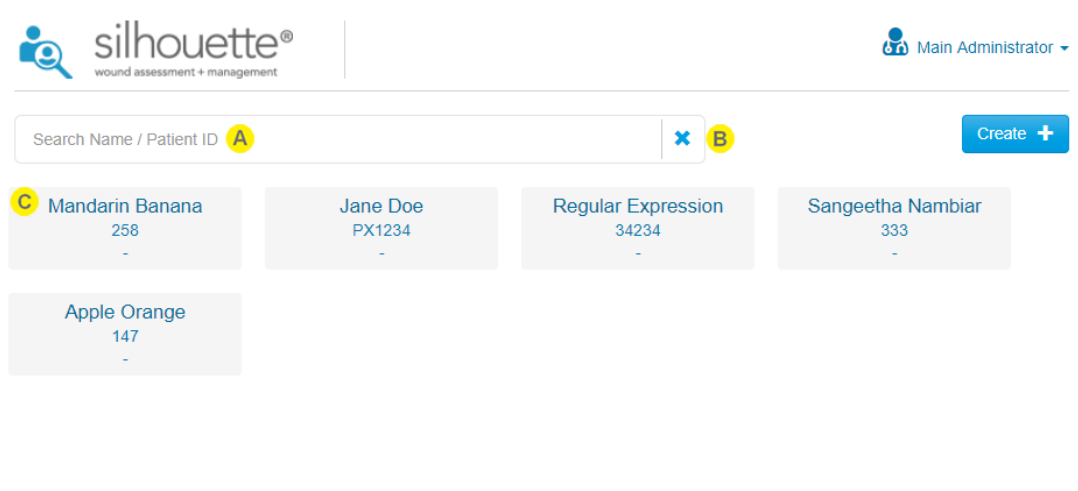

### A Search box

Enter part of the patient's name or Patient ID. The search will be performed after the typing has stopped. For example, searching for the letters "an" filters the list so that it displays patients whose name or Patient ID begins with the letter sequence "an".

Narrow the search further by entering more of a patient's name or Patient ID.

### B Clear button

Select the x button to clear the search box and display the full list of patients.

### C Search results

The patients that match the search criteria entered are displayed below the search box as a set of tiles. Select the patient tile to view the patient overview.

## Patient Banner and Sidebar

Once a patient is selected a patient banner is displayed at the top of the screen and a sidebar is displayed on the left that can be used for navigating between sections.

The sidebar can be expanded and collapsed, and the currently selected section is highlighted in blue in the sidebar.

The screenshot displays the patient banner and sidebar interface. The banner at the top shows the patient's name 'London Eye', ID '555-0002', and date of birth '1999-12-31'. A camera icon in the top right of the banner indicates 16 images in the portfolio. The sidebar on the left is expanded, with 'Overview' selected and highlighted in blue. Other sidebar items include 'Details', 'Investigation History', 'Medical History', 'Medication', 'Orders', 'Wounds' (with a '+ Wound' button), and 'Inactive'. The main content area shows 'Patient Summary' with three cards: 1 Active Wounds, 14 Assessments, and 21 Years old. Below this is an 'Active Orders' table with one row for a Wound Assessment.

Order Number	Account Number	Scheduled
0000000030	AC000000029	2021-04-10 10:55

- A** Select the patient search icon or the logo to go back to the **Patient Select** screen.
- B** The patient banner shows at the top of the screen and includes the positive patient identifiers and access to the image portfolio.  
Select the camera icon to open the image **Portfolio**, containing the unassigned captured images and the SilhouetteStar connection information.
- C** The sidebar can be collapsed or expanded.
- D** The selected sidebar item is highlighted.  
Select **Overview** to open the Patient Summary.
- E** Select **Details** to open the Patient Details screen. The remained of the patient note sections available on the sidebar are configurable in the Admin section.
- F** Select **Orders** to see a list of all orders for the patient, if the system is configured for use with orders.
- G** The list of wounds is shown in the sidebar, grouped by active and inactive status.
  - Select a wound from the list to open the Wound Overview.
  - Selecting the + **Wound** button to create a new wound.

## 20 • Patient Banner and Sidebar

Note that it is possible to use multiple tabs to view SilhouetteCentral. Care should be taken to ensure the correct patient data is being reviewed when using this feature.

## Capturing Wound Images



To get more comprehensive help with the Clinical UI in Silhouette, please see the Clinical User's Guide.

In order to capture wound images, Silhouette must be connected to a SilhouetteStar device.

### Connecting a SilhouetteStar to SilhouetteConnect using USB

SilhouetteConnect allows connection of either the SilhouetteStar 1 or the SilhouetteStar 2 device via a USB cable. The USB connected device automatically connects, if plugged in, once as the user is logged in to SilhouetteConnect. To check that the device is detected and connected, either check the screen of the SilhouetteStar 2 or navigate to the portfolio dialog for a patient. The Portfolio dialog is accessed by selecting the **camera icon** in the Patient banner.

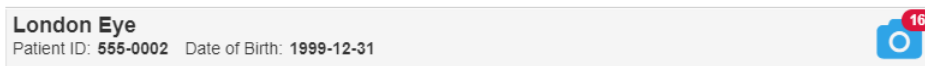

The portfolio dialog provides a message indicating that the device is connected and is ready to capture images.

### Connecting a SilhouetteStar 2 to SilhouetteCentral using Wi-Fi

SilhouetteCentral allows connection of the SilhouetteStar 2 using Wi-Fi. For this, Silhouette needs at least one SilhouetteStar 2 network configured. See [Creating a Network Configuration](#).

To connect the device to SilhouetteCentral via Wi-Fi:

1. Open the Portfolio dialog by select the **camera icon** on the Patient banner.

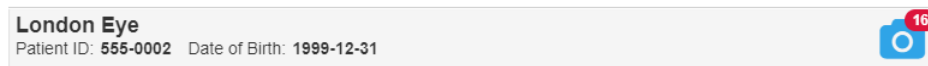

2. If the Portfolio shows the captured images instead of the networks available, use the **Connect the SilhouetteStar** link.
3. The dialog will display a QR code. If there are multiple SilhouetteStar 2 networks configured, it will show a dropdown so that the correct network can be selected.
4. Press the button on the SilhouetteStar 2 to turn on the lasers.
5. Hold the SilhouetteStar 2 with the button facing up and form a star with the lasers on the QR code to connect to Silhouette.

Once it has connected, the Patient details will be shown on the SilhouetteStar 2 display, and images can be captured.

## Using the SilhouetteStar to capture images

Images can be captured whenever the SilhouetteStar device (SilhouetteStar 1 or SilhouetteStar 2) is connected and there is a patient selected.

To capture images:

- Press the button on the SilhouetteStar to turn the lasers on.
- Form a star with the lasers inside the wound, making sure one laser is crossing the deepest part of the wound.
- Press the button on the SilhouetteStar to take the image, holding the device as still as possible for approx. 2 seconds. The SilhouetteStar 1 initiates the image capture when the button is pressed, while the SilhouetteStar 2 initiates the image capture when the button is released.
- The lasers turn off after a timeout. If the lasers turn off and there are still more images to be captured, then press the button to turn them on again.

Captured images are uploaded to the selected patient's portfolio and can be used when creating assessments. If using SilhouetteConnect, the images in the patient's portfolio are stored locally on the computer and are not synchronized to SilhouetteCentral. Images stay in the portfolio until they are used in an assessment or until they are deleted by the user.

The user is able to navigate between patients in Silhouette while the SilhouetteStar device is connected. When using a Wi-Fi connection to SilhouetteCentral, the SilhouetteStar 2 patient selection is synchronized to the user session in the browser tab it was originally connected to. If that browser tab is closed then the device is disconnected and must be re-connected to another browser tab by scanning the connection QR Code in that tab.

## Disconnecting the SilhouetteStar

The SilhouetteStar will remain connected until the Silhouette user session ends (e.g. by logging out, by application lock timeout, by closing the web browser, etc).

When operating in Wi-Fi mode, the SilhouetteStar 2 will go to sleep after a period of inactivity to preserve the battery power. When the button is pressed, the device will wake up and attempt to reconnect to the last user session. If that user session has ended then the device will display a failed to connect message. Connect it to another session by scanning another connection QR Code.

If using the SilhouetteStar 2, the internal battery needs to be changed, even when operating in a USB connected configuration.

## Logging Out from Silhouette

You can log out of Silhouette by using the Application Menu in the upper right-hand corner, and selecting the **Logout** option.

Note that you will be automatically logged out of Silhouette after a period of inactivity. This period is configurable, but by default is 10 minutes.

## Silhouette Concepts and Operation

This section describes the basic concepts used within Silhouette and the details of various features and operations. It is divided into the following topics:



[Clinical Groups, Clinical Users, and Units in Silhouette](#)



[Home Users in Silhouette](#)



[Assessments and Patient Notes](#)



[Wounds](#)



[Orders and Encounters](#)



[System Events](#)



[Assessment Email](#)



[Silhouette Integration](#)

### Clinical Groups, Clinical Users, and Units in Silhouette

Silhouette can optionally support two different types of users, Clinical Users and Home Users. This topic relates to Clinical Users. [See Home Users in Silhouette](#) for details relating to Home Users.

For clinical Users, access to patient data in Silhouette is managed through Units and Groups. Additionally, the Group controls application permissions (functionality) assigned to the User.

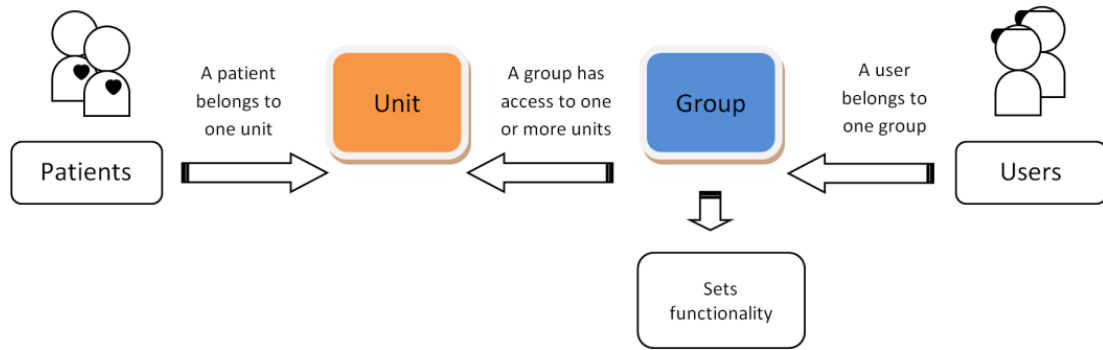

Where:

- Every patient belongs to a single Unit. The Unit they belong to can change over time.
- Each user belongs to a single Group.
- A Clinical Group can be associated with any number of Units within the system.

A Silhouette Clinical User has access to:

- Patients that belong to the Unit(s) their assigned Group has access to; and
- Perform actions that are allowed by the Group permissions.

As an example, your organization might have Group of Users that can only access patients from a specific Unit in the system and only create new data, while another Group of Users might be limited to the same Unit but can also edit data. A different Group of Users might have access to every patient and can use any feature available in the system.

It is possible to create a Group that doesn't have access to any Units. In this case, the assigned Users will not be able to view any clinical data. This can be useful for setting up Users that are able to receive emails from the system but should not be able to view any patient data or to have administrators looking after application settings and configuration who do not have access to patient data.

A patient's assignment to a Silhouette Unit is an important way of controlling who has access to patient data and, subsequently, how much patient data users will store in offline capable applications (SilhouetteConnect, SilhouetteLite+ or SilhouetteLite).

Organizations use Units in different ways, depending upon how the organization is structured. For example, an organization may use Units to differentiate different departments, wards, or facilities. Clinical research organizations typically create a Unit per research site.

When implementing Silhouette for your organization, first define and configure Units, then Groups and finally Users.

## Provisioning Units and Groups

Units can be defined in the **Admin > Units** screen.

The selection of Units a Group can access is defined in the **Admin > Groups** screen.

The assignment of a patient record to a Unit is initially set on patient record creation or edited from the patient sidebar **Details** screen.

When using integration from an EMR system to create and update patient records in Silhouette, the unit a patient record is assigned to is typically mapped from a facility.

## Provisioning Users

There are two ways to provision user records in the system.



Silhouette local user records are created and edited from within the Silhouette application on the **Admin > Users** screen. These user records are configured in Silhouette with the following attributes:

- First name
- Last name
- Middle name
- Email Address
- User Name
- Password
- Silhouette Group Assignment

User who are authenticated by external authentication providers have user records provisioned in the Silhouette database when they log in, commonly known as Just-In-Time (JIT) Provisioning. These user records are managed in an external directory (e.g. Active Directory) and are updated in Silhouette only when that user logs in to Silhouette again.

- External provider user records in Silhouette are updated when the user logs in.
- The external provider user assignment to Silhouette permissions is through dynamic mapping of external group membership to Silhouette Groups. Their group mapping is checked each time they login and their Silhouette assignment is adjusted according. The mapping is configured in the **Admin > Groups** screen.
- Silhouette expires unused external provider user records after a set period (nominally 90 days) of inactivity. This expiration is so that users that are disabled in the remote directory will not show as active forever in Silhouette, as a user record is only updated when a user logs in. If an infrequent but active user gets their record expired it automatically gets provisioned again the next time they login.
- External provider user records, for users who have been recently active, can be viewed but not edited in the **Admin > Users** screen. When viewing the record in Silhouette you see the record as it was updated when the user last logged in.
- The Silhouette system can not list all external provider users who have access but have not logged in, or users that did have access and have been removed. This information is available from the external user directory where the user records are managed.

The Silhouette system can be configured to enable each type of user independently, but new deployments always start with Silhouette Local Users enabled. To use external authentication providers for SSO and JIT provisioning, the system requires the SSO Integration optional feature to be licensed.

## Importing Groups, Users and Units

If you have access to the physical server running SilhouetteCentral you can alternatively make use of a more direct import process, as an alternative to using the administration user interface to configure additional groups, users, or units.

Files with the following special filenames can be placed in the Files\Setup folder of SilhouetteCentral's installation folder and will be automatically detected and processed during the next application pool restart. If successfully processed, the file will be deleted from the Files\Setup folder to indicate its successful import.

- Units.csv - a comma separated list of units to import into Silhouette.
- Groups.csv - a comma separated list of groups to import into Silhouette.
- Users.csv - a comma separated list of users to import into Silhouette.

As an example if you wanted to quickly add 50 additional units to a Silhouette installation you could create a Units.csv file describing the details of the 50 additional units and then place this file in the Files\Setup folder. Once the file is in place, restarting the IIS application pool would cause the 50 units to be imported into the system.

Please contact ARANZ Medical Limited support for assistance preparing the csv files for importing.

## Home Users in Silhouette

Silhouette can optionally support two different types of users, Clinical Users and Home Users. This topic relates to Home Users. [See Clinical Groups, Clinical Users, and Units in Silhouette](#) for details relating to Clinical Users.

Home user access is an optional feature of Silhouette, which is useful if you want patients to provide images and some basic assessment of their own wounds from their own home. Home users get access to login to the SilhouetteCentral website and see their own patient record. They can also be granted the right to submit images and basic assessment notes to their patient record for a clinical user to review remotely.

For home users, access to patient data in Silhouette is managed through direct association to patient records. The home user account is still associate to a group, which controls which functionality is available to the user.

Group settings are defined in the [Groups](#) screen. Home user accounts can be created from the Home User Access section of the relevant patient record and can be edited in the [Users](#) screen.

The Home User Access feature of Silhouette requires that the SilhouetteCentral website is available in patient's homes and on patient devices. Enabling this may require some changes for customers hosting SilhouetteCentral on premise or in a private cloud. Before utilizing the Home User feature it is advised to perform a Privacy Impact Assessment to if you have adequate privacy controls in place.

When configuring Silhouette Home User for your organization:

- Give a clinical user the "Can Manage Home Users" permission.
- Update the Home Wound Assessment to make sure it captures the data you wish to gather from your home users when they image a wound.
- Create a Home User group defining the application rights you wish the home users to have.
- Update the Home User Welcome Email to include a link to your privacy statement and any terms of use you wish to share with the home users. You may also want to update the welcome email with any basic instructions or home imaging guidance you wish to give the home users.
- Identify patients who will benefit from imaging at home and are also capable of imaging at home. This includes determining if they have a device that can capture images and submit them using the SilhouetteCentral website.
- Set the patient (or their nominated representative) up with a Home User account and provide any training on the data you would like them to submit. This is typically done when they are present with the clinician, either as an inpatient or when they are visiting a clinic.

## Assessments and Patient Notes

Assessments and Patient Notes are the method used in Silhouette to record information about a patient and their wounds.

### Assessments

Assessments are the main charting method within Silhouette. Assessments appear on a patient's timeline and represent a set of data recorded at a point in time. Silhouette allows for two different types of assessments:

- Patient Assessments, which are about the patient as a whole (rather than a particular wound) and are useful to record patient risk assessments or similar whole of patient assessments.
- Wound Assessments, which are about a particular wound on the patient and are the main assessment used to track progress of a given wound.

Silhouette comes with some pre-loaded Patient Assessments and Wound Assessments. Extra assessments can be added to the system to suit your organization.

Assessments are key concept when getting your data out of Silhouette.

- A user can create and download a PDF report of an Assessment. See the Clinical User's Guide for more detail.
- The csv data exports available from Silhouette are largely structured as an export of all data for an assessment type. The exception is the wound export that exports non-assessment based data. [See Clinical Data Export](#) for more detail.
- The email notifications available from Silhouette are based on user interactions with assessments, either assessments getting created and/or assessments being edited. [See System Events](#) for more detail.
- The integration messages out of Silhouette are based on user interaction with assessments, either assessments getting created and/or assessments being edited. [See System Events](#) for more detail.

### Patient Notes

Patient notes are like assessments except they do not relate to a point in time and record information about the patient as a person. For example, a patient's allergies may change over time but they are not assessed every week. Patient Notes appear in the patient sidebar whenever viewing the patient and can be appended to assessment reports.

## Wounds

Wounds (or regions of interest) are the key concept within Silhouette allowing measurements to be tracked longitudinally. Silhouette uses the wound concept to group images and measurements and graph and compare relevant measurements over time.

Measurements can be made from images in both patient level and wound level assessments, however, only wound level assessments provide the longitudinal tracking of progress.

A wound in Silhouette has the following properties:

- A wound has a label, which is allocated by Silhouette and is unique within the patient. The label can be numerical or alphabetical.
- A wound is referenced to an anatomical location or site.
- A wound has a status, open or closed. Within these wound status' there can be multiple wound states. In the default configuration there is one open status (Open) and multiple closed status' (Healed, Released from Follow-up, or Amputated).
- A wound has a single baseline date which is used to track area reduction. The baseline area measurement is the first non-zero area measurement on or after the baseline date. Authorized users can set the baseline date if you want to restart the tracking of wound healing based on an event (e.g. wound recurrence, a treatment plan change or subject acceptance into a research project).

## Orders and Encounters

SilhouetteCentral supports orders to allow integration with EMR systems and provide a convenient way to provide a work list. An order in Silhouette can only be created using the Silhouette Integration Interface and always belongs to an Encounter, which in turn belongs to a Patient record. The Encounter record can only be created through the Silhouette Integration Interface and provides a mechanism to link assessments to a temporary or encounter based patient identifier (e.g. an account number).

- An order can be created as a request for a particular assessment type or for any assessment type.
- An order can must have a unique order id and have a schedule date.
- An order can have a maximum number of assessments specified, which provides a warning if there are more than the specified number of assessments linked to the order when the user attempts to complete the order.
- An order must belong to one encounter, which in turn must belong to one patient.
- A patient record can have more than one encounter, which in turn can have more than one order.
- An assessment can be linked to more than one order, over multiple encounters for the same patient.

The typical order workflow is:

- An order is created and signed in an EMR system, resulting in an HL7 message to Silhouette.
- The wound care provider logs into Silhouette and finds or performs an assessment that they wish to send to the EMR system. They may or may not use the presence of the active order to signal that there is a wound assessment to perform.
- The wound care provider links the assessment to the appropriate order.
- The wound care provider marks the order as completed.
- Silhouette sends the results of the assessment to the EMR system based on either the order being completed or the order and assessment being linked, or both. The order, encounter and patient identifiers provide the EMR system with the information required to ensure the assessment results are made available in the correct part of the EMR system.

## System Events

System events are used as triggers to send emails or send integration events.

System events are created when a user creates or updates an assessment.

When using SilhouetteCentral:

- An **Assessment Created** system event is generated whenever the user presses the **Save** button after pressing the **+ Patient Assessment** or **+ Wound Assessment** buttons.
- An **Assessment Updated** system event is generated whenever the user presses the **Save** button after pressing the **Edit** assessment button and making some edits to the assessment.
- An **Assessment Updated** system event is generated whenever the user performs a Change Date or a Move Assessment data administration on the assessment.
- An **Order Linked** system event is generated whenever the user links an assessment to an order.
- An **Order Unlinked** system event is generated whenever the user has unlinked an assessment from an order.
- An **Order Status Changed** system event is generated whenever the user updates the status of an order.
- System events are not generated when an assessment is deleted.

When using SilhouetteConnect, system events are generated when the user performs a **Sync** with SilhouetteCentral:

- An **Assessment Created** system event is generated when a user has created an assessment within SilhouetteConnect.
- An **Assessment Updated** system event is generated when a user has edited an assessment within SilhouetteConnect.
  - Only one assessment system event is generated for an assessment regardless of the number of times it has been edited offline. If an assessment is created and then edited before a **Sync** is performed, then a single **Assessment Created** system event is generated for that assessment after **Sync**.
- An **Order Linked** system event is generated when a user has linked an assessment to an order within SilhouetteConnect.
- An **Order Unlinked** system event is generated when a user has unlinked an assessment from an order within SilhouetteConnect.
- An **Order Status Change** system event is generated when a user has completed an order within SilhouetteConnect.
  - A SilhouetteConnect **Sync** can generate multiple **Order Linked** and **Order Unlinked** events if multiple actions are performed prior to performing a **Sync**.

When using SilhouetteLite or SilhouetteLite+, an **Assessment Created** system event is generated when assessments are uploaded to SilhouetteCentral.

An **Assessment Updated** system event is not generated when items not recorded as part of an assessment are changed. For example, editing a wound description or a patient name does not cause a **Assessment Updated** system event.

## Assessment Email

Silhouette assessment email is only available in SilhouetteCentral if the SilhouetteCentral license includes the Assessment Email Actions optional feature.

Assessment email is setup by:

- Performing Email Configuration.
- Creating Email Lists.
- Creating Assessment Email Actions.

The Silhouette Assessment Email works by going through the following steps:

- Periodically looking at a queue of system events (see [System Events](#)), checking the configured Assessment Actions for send email triggers, generating the required email content, generating any required attachments and placing the emails into a email queue.
- Periodically taking pending emails from the email queue and sending them via the configured SMTP email service.
- Periodically taking failed emails from the email queue and retrying them via the configured SMTP email service.
- Periodically purging old system events and emails from the queues.
- Recording the email actions in the email log.

## Sending Email

Emails are sent via the configured SMTP server and a retry policy is applied if the email fails initially. With a default configuration and a low number of emails per minute being generated then an email should typically be submitted to the SMTP service within 1 minute of the system event which causes the email. Some of the policy around email sending is documented below:

- No emails older than a maximum number of days will ever be sent (default = 10 days). This policy can come into play if the SMTP email configuration has been disabled for some time and then it is later switched it on or if an old system backup is restored that had emails in the queue.
- Pending emails (ones that have never been attempted) are sent before emails that need to be retried.
- Failed emails that are pending retries are retried with increasing delay between each try. The email retry policy attempts to send approximately 10 times over 5 days, with more frequent attempts earlier in the period and less frequent attempts later in the period.
- If the email can not be sent successfully after all the retry attempts, then it is marked as failed permanently and does not get automatically retried.

## Email System Configuration

There are system configuration items that can be set to control the email behavior. The configuration includes control of:

- The period of the jobs which process system events and send emails.
- The number of system events that will be processed in any one period.
- The number of emails that will be processed in any one period.

- The number of emails that will be submitted concurrently to the SMTP service.
- The number of days to keep the system events and emails in the queues.

Refer to the Configuration and Installation Guide for more details on these configuration items.

## Email System Auditing

The email system audit information is kept in the email log, typically located on the SilhouetteCentral server in a directory called <application root>\files\logs. A new log is created daily and contains the following details:

- What the email system is doing.
- What system events are causing emails to be queued.
- Who (which system user) caused the system event.
- What assessment the system event is related to.
- When emails are being sent.
- Who emails are being sent to including the destination email address.

The information, except for destination email address, about users and assessments in the log file is presented as database identifiers, so access to the database is required to decode the identifiers to real data about patients and users.

If this information is important for your audit purposes then make sure the log files are backed up appropriately.



## Silhouette Integration

Silhouette integration is only available in SilhouetteCentral if the SilhouetteCentral license includes the Silhouette Integration Interface optional feature.

Silhouette supports integration to other customer IT systems using standardized HL7 v2 messaging and PDF documents when deployed with an instance of a third party open source integration engine called NextGen Connect (previously Mirth Connect). The interface between SilhouetteCentral and NextGen Connect is a non-standard Silhouette integration interface.

The initial configuration of SilhouetteCentral and NextGen Connect for integration requires the support of ARANZ Medical during system deployment.

It is common to already have an integration engine deployed as part of the hospital IT system. The deployment of a specific instance of NextGen Connect for Silhouette is required as the configuration management of SilhouetteCentral and NextGen Connect is tightly coupled, i.e. a change in one application often results in a change in the other application.

Integration is separated into two main categories:

- Inbound integration where data flows from an external system into Silhouette, see [Silhouette Inbound Integration](#).
- Outbound integration where data flows from Silhouette into an external system, see [Silhouette Outbound Integration](#).

## Silhouette Inbound Integration

The inbound integration is typically an HL7 data feed originating from a hospital EMR system being used to create and update patient records within Silhouette.

An example inbound integration data flow is shown in the image below for creating and updating a patient.

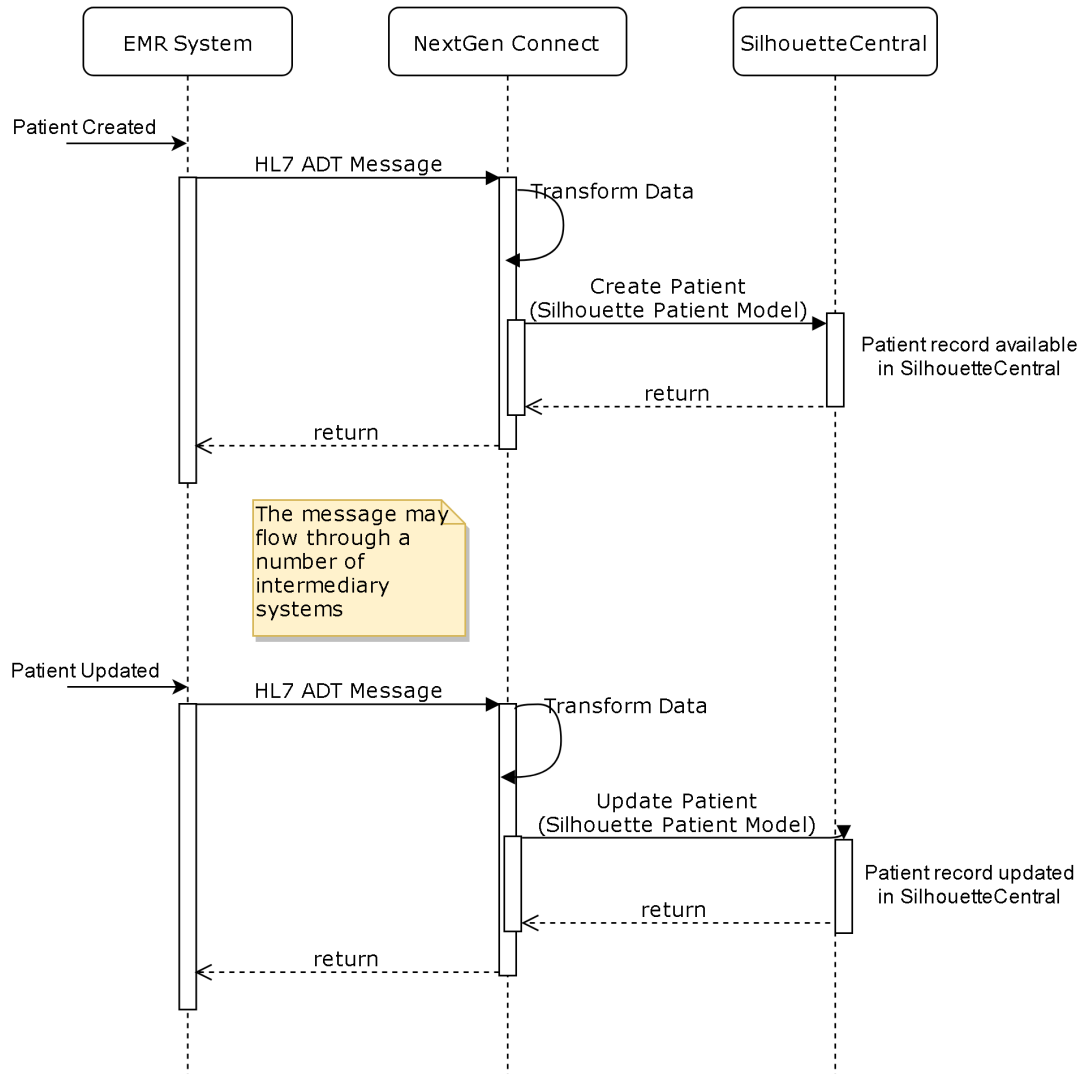

Silhouette allows a set of note fields to be flagged as integration identifiers for the relevant entity and can be independent of the identifiers used by users to find and identify entities in the Silhouette user interface. Integration identifier fields are used as the fields to match HL7 messages to Silhouette records.

- The integration identifiers for a patient are usually one or more of the patient identifiers from the HL7 PID.3 field or the Account number from the HL7 PID.18 field.
- The integration identifiers for an encounter is usually a visit number or an account number.
- The integration identifier for an order is always the order number.

The configuration steps involved to enable a successful inbound integration are:

1. Install an instance of NextGen Connect for Silhouette integration.
2. Configure SilhouetteCentral with an appropriate group and user for the Silhouette integration instance of NextGen Connect to use, see [Creating a Group](#) and [Creating a Silhouette Local Clinical User](#).

3. Configure SilhouetteCentral to indicate which note fields are Integration Identifiers.
4. Configure a machine to machine VPN to encrypt HL7 messages between the EMR System and NextGen Connect. This step is optional and can be skipped on the approval from the applicable security officer.
5. Configure the EMR System or intermediary system to send the appropriate HL7 messaging to the Silhouette integration instance of NextGen Connect.
6. Configure NextGen Connect channels to receive HL7 messages, translate them into the Silhouette Integration Model (see [Inbound Integration](#)) and forward them to SilhouetteCentral.

Of the above steps, only step 2 is covered in the scope of this guide. However, to enable a successful integration, ARANZ Medical staff can assist in all steps of the setup as part of a system deployment project.

Silhouette supports the following actions on the integration interface:

- Patient create / update / delete / merge
- Encounter create / update
- Order create / update

An HL7 conformance document is available on request to ARANZ Medical Support.

## Silhouette Outbound Integration

The typical outbound integration is the generation of a wound assessment report from Silhouette and the subsequent loading that report onto the patient record in another hospital IT system.

The typical outbound integration data flow is shown in the image below.

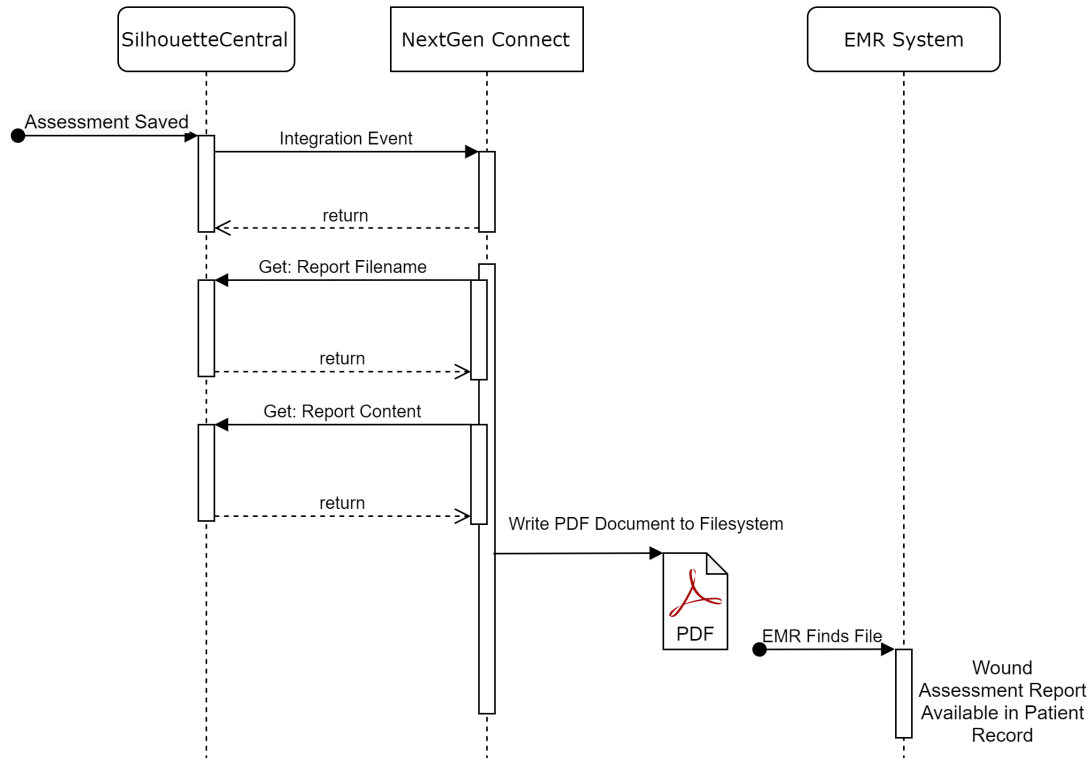

The generation of Integration Events are based on the System Events (see [System Events](#)) and Assessment Actions. The Silhouette integration event sending works by going through the following steps:

- Periodically looking at a queue of system events (see [System Events](#)), checking the configured Assessment Actions for send integration event triggers, generating the required integration event content and placing the integration event into a integration event queue.
- Periodically taking pending integration events from the integration event queue and sending them to the configured outbound integration interface.
- Periodically taking failed integration events from the integration event queue and retrying them.
- Periodically purging old system events and integration events from the queues.

The Integration Events do not include any patient data, just identifiers which can be used to retrieve data from Silhouette. Further details of Integration Events are outside the scope of this guide.

The configuration steps involved to enable a successful outbound integration are:

1. Install an instance of NextGen Connect for Silhouette integration.
2. Configure an IIS reserves proxy with certificates to terminate an HTTPS channel for the encryption of the Integration Events from Silhouette to NextGen Connect. This step is not required if NextGen Connect is on the same server as Silhouette.
3. Configure SilhouetteCentral with an appropriate group and user for the Silhouette integration instance of NextGen Connect to use, see [Creating a Group](#) and [Creating a Silhouette Local Clinical User](#).

4. Configure SilhouetteCentral to sending integration events to NextGen Connect, see [Outbound Integration](#).
5. Configure SilhouetteCentral Assessment Actions to send integration events, see [Creating an Assessment Action](#).
6. Configure NextGen Connect with appropriate channels to receive the Integration Event and do some or all of the following:
  - a. Create the PDF assessment report in a location shared with the EMR with the correct report name or supporting meta-data file.
  - b. Export the images from the assessment in a location shared with the EMR with a known name or supporting meta-data file.
  - c. Send an HL7 results message with embedded PDF assessment report, Images or the raw measurements and notes as observations to an EMR system.
7. Configure the EMR system to monitor the shared file location or listen for the HL7 results messages and ingest the data appropriately.

Of the above steps, only steps 3, 4 and 5 are covered in the scope of this guide. However, to enable a successful integration, ARANZ Medical staff can assist in all steps of the setup as part of a system deployment project.

## Clinical Data Export

Silhouette Clinical Data Export is an optional feature that can be enabled in a Silhouette license. The feature can be added to a license for either SilhouetteConnect (applies to standalone mode only) or for SilhouetteCentral.

A clinical data export extracts patient, wound and assessment data into a comma separated values (CSV) file. See [Appendix F: Clinical Data Export Format](#) for more details on the data export format.

It is the responsibility of the person requesting and saving the data export output to protect that data once it is exported.

To perform an assessment data export the user performs the following steps:

- A user must have the **Can Export Data** permission.
- An export can be generated by selecting **Export > New Export** from the application menu or by selecting **Export Assessments** from the patient overview. [See Creating a New Data Export.](#)
- Once the export is completed then the export can be downloaded by selecting **Export** from the application menu. [See Downloading a Data Export](#)



Clinical data exports create clear text documents containing patient information. Take care to protect the privacy of the exported data. Files downloaded from Silhouette need to be stored and transmitted in compliance to your organizations data privacy policies and procedures.

The Silhouette system performs the export by:

- New clinical data export requests are queued and executed one at a time.
- The export is performed by taking a temporary copy of the data to be exported. This is to minimize the amount of time that people can be changing data on the system as the data is being exported.
- The data is transformed into the export format and made available for download.
- In SilhouetteCentral, a file cleanup is run once a day. The file cleanup removes any exported files that are more than 3 days old (or the configured setting).
- In SilhouetteConnect, a file cleanup is run whenever a user logs in. The file cleanup removes any exported files that are more than 3 days old (or the configured setting).
- In SilhouetteConnect, an exported file is also removed from the system once the user has requested the download. The file is removed even if the user cancels on the Save File dialog.

The clinical data export includes the current active data in Silhouette, which includes any data changes or corrections made.

### Creating a New Data Export

There are two ways to create a new data export.

- Clinical data export for multiple patients within a given date range.
- Clinical data export for a single patient.

To create a new data export your Silhouette user group needs the permission *Can Export Data*.

## Clinical Data Export for Multiple Patients

To export data for multiple patients in either SilhouetteCentral or a standalone SilhouetteConnect:

- Select the **Export** option from the application menu to show the Clinical Data Exports screen.
- Select the **New Export** button from the Clinical Data Exports screen on Silhouette.

The Create Clinical Data Export screen is shown and is used to complete a new data export request for multiple patients.

### A Export Type

Select the **Export Type** you wish to export from the list. A single assessment type or a wound export can be selected.

To export all assessment data, create an individual export request for each assessment type.

Wound assessment exports also include the wound state captured at the time of the assessment.

However, use the **Wound** export to export all wound state information, including wound state that has been set without performing a wound assessment (e.g. initial creation of the wound).

### B Unit

Select the unit(s) you wish to export data from. Selecting **All Units** will export data for all patients that you have access to in Silhouette.

### C From and To

Enter a date range for the assessments to include in the export.

The To cannot be less than the From date.

The date range entered is inclusive of assessments performed on that day. All assessments with a date time recorded from the beginning of the day on the **From** date to the end of the day on the **To** date are included in the data export.



There is no enforced limit on the date range you can enter. However, the Silhouette system places a 10 minute timeout on the database transaction used for data export and the export will fail. In this case, export the data in multiple exports covering smaller date ranges.

The number of assessments that can be included in a single export will depend on your specific database configuration.

**D Time Zone**

Select the **Time Zone** that is used to determine what the precise time the start of the **From** day is and the end of the **To** day is. The time zone options are limited to your local PC time zone setting or UTC (Coordinated Universal Time).

The selection of the time zone does not change the data exported, just the selection of which assessment data to export.

For example:

- There is an assessment recorded in the system with the date 28th of Feb 2018 at 1800 hours America/Los Angeles (Pacific Standard Time or UTC-8) which equates to 1st of March 2018 at 0200 hours UTC.
- Selecting to export assessments **From** the 1st of March 2018 based on the America/Los Angeles time zone will exclude the assessment from the export as it is before the 1st of March 2018 at 0000 hours in the America/Los Angeles time zone.
- Selecting to export assessments **From** the 1st of March 2018 based on the UTC time zone will include the assessment from the export as it is after the 1st of March 2018 at 0000 hours in the UTC time zone.
- The assessment date in the data export is 2018-02-28T18:00:00+8 and the assessment time zone is America/Los Angeles regardless of the **Time Zone** selection when creating the export.

**E Export**

Select the **Export** button to create the export request.

The Clinical Data Export screen will be shown with the newly created export highlighted in the table, see [Downloading a Data Export](#) for more details.

**F Cancel**

Select the **Cancel** button to cancel the export request.



## Clinical Data Export for a Single Patient

To export data for a single patient (includes all assessments of that type without specifying a date range):

- Navigate to the Patient Summary screen for the patient by selecting **Overview** in the patient sidebar.
- Select the **Export** button from the top of the screen.

The Export Clinical Data dialog is shown and can be used to complete the data export request for the patient.

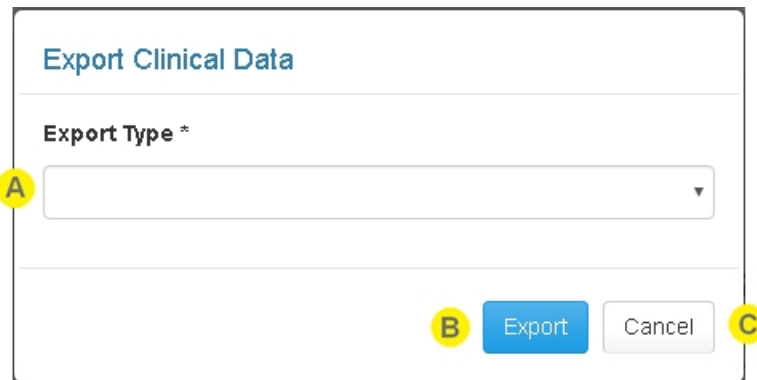

### A Export Type

Select the **Export Type** you wish to export from the list. A single assessment type or a wound export can be selected.

To export all assessment data, create an individual export request for each assessment type.

Wound assessment exports also include the wound state captured at the time of the assessment. However, use the **Wound** export to export all wound state information, including wound state that has been set without performing a wound assessment (e.g. initial creation of the wound).

### B Export

Select the **Export** button to create the export request.

The Clinical Data Export screen will be shown with the newly created export highlighted in the table, see [Downloading a Data Export](#) for more details.

### C Cancel

Select the **Cancel** button to cancel the export request.

## Downloading a Data Export

To download a data export, select the **Export** option from the application menu to access the Clinical Data Exports screen in SilhouetteCentral or SilhouetteConnect (standalone mode only).

The Clinical Data Exports screen is also shown whenever you create a new data export, see [Creating a New Data Export](#).

Created <b>A</b>	Status <b>B</b>	Export Type <b>C</b>	Filter <b>D</b>	<b>E</b>
2019-07-26 15:47	Ready for Download	Wound	Patient PA-000001	Download
2019-07-26 15:47	Ready for Download	Wound Assessment	Patient PA-000001	Download
2019-07-26 15:47	Ready for Download	Lower Limb Assessment	Patient PA-000001	Download
2019-07-26 15:48	Ready for Download	Wound	Date range 2019-01-01 13:00 to 2019-07-01 12:00. Patients from all units.	Download
<b>2019-07-26 15:48</b>	<b>Ready for Download</b>	<b>Wound Assessment</b>	<b>Date range 2019-01-01 13:00 to 2019-07-01 12:00. Patients from all units.</b>	Download

**F** New Export

The table on the Clinical Data Exports screen shows the exports that are currently running or are finished and available to download. You can see and download only data exports which you have created.

If there are no exports to download there will be no table and a message stating that there are no exports to download.

### **A** Created

The date and time the export was requested.

### **B** Status

Shows the current status of the export. When an export is created it goes in to a queue of exports and the Silhouette system will run one export at a time.

The status refreshes at a rate of approximately 15 seconds.

Valid statuses that can show are:

- Queued - the request is in the data export queue waiting to start.
- Running - the export is currently being attempted.
- Failed - the export failed. Review the silhouette central log file for more insight into the failure. A typical reason for failure may be that the requested export was too big. The recommendation is to retry the export by creating a new export with a smaller date range and or a smaller set of units.
- Canceled - the export was canceled by the user prior to it finishing.
- Ready for Download - the export has successfully completed and is ready for download.

### **C** Export Type

The export type column lists the type of data included in the export.

### **D** Filter

The filter column provides a summary of the filter used to create the export.

**E** If there is an action available for the export then a button is available on the right of the table.

Valid actions are:

- **Cancel.** Cancels the export creation if the status is Queued or Running.
- **Download.** In SilhouetteCentral this action downloads the export to your web browsers default download directory. In SilhouetteConnect this action causes a Save dialog to show and you can select a location to save the export to. In SilhouetteConnect the Download action can only be used once and causes the export to be removed from the system.

If the status of the download has changed by the time you press the action button, then a prompt to refresh the screen is shown and the action is not performed.



Clinical data exports create clear text documents containing patient information. Take care to protect the privacy of the exported data. Files downloaded from Silhouette need to be stored and transmitted in compliance to your organizations data privacy policies and procedures.

**F** **New Export**

Select the **New Export** button to create a new export request, see [Creating a New Data Export](#) for details.



Clinical data exports are removed from Silhouette after a number of days (the default is 3 days). If you do not download them, or want them again, they will need to be regenerated.

# Silhouette Administration

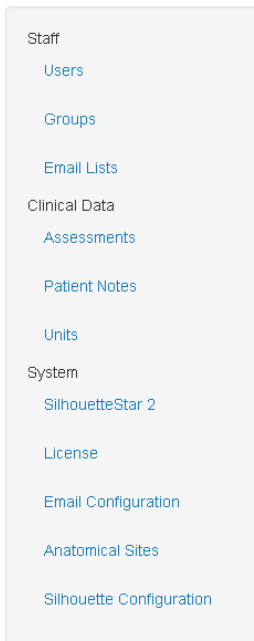

Silhouette administration is controlled through either SilhouetteCentral or SilhouetteConnect, see [Using Silhouette](#).

The administration options available depend on what application you are using and what mode it is operating in. Each administration topic identifies specific application and mode dependency. A high level description of application and mode dependency is listed here:

- SilhouetteCentral (any mode) contains most administration, except wired mode specific settings for SilhouetteStar 2.
- SilhouetteConnect, Synchronized mode contains only administration settings applicable to the administration of the specific PC. All system wide settings are configured in SilhouetteCentral and updated in SilhouetteConnect when a synchronization is performed.
- SilhouetteConnect, Standalone mode contains a subset of all system administration. Settings that are not applicable to standalone (non-enterprise) settings are not available.

The admin section is accessed through the **Application Menu** and is organized into sections, which are selected from the left hand sidebar.



[Users](#)



[Groups](#)



[Email Lists](#)



[Assessments](#)



[Patient Notes](#)



[Unit Administration](#)



[SilhouetteStar 2](#)



[License](#)



[Email Configuration](#)



[Anatomical Sites](#)



[Silhouette Configuration](#)



The sections displayed to a user will depend upon their assigned permissions.

## Users

Users must have a user account to access any of the Silhouette applications (SilhouetteCentral, SilhouetteLite, or SilhouetteLite+). The **Users** screen allows you to:

- Add and manage Silhouette local clinical user accounts.
- Manage home user accounts.
- View a list of recently active SSO user accounts. Recently active usually means that they have logged in to Silhouette within the last 90 days.

To define and manage users, select **Admin > Users**. The **Users** option is not available in SilhouetteConnect when it is running in synchronized mode. In Synchronized mode, user administration is performed in SilhouetteCentral.

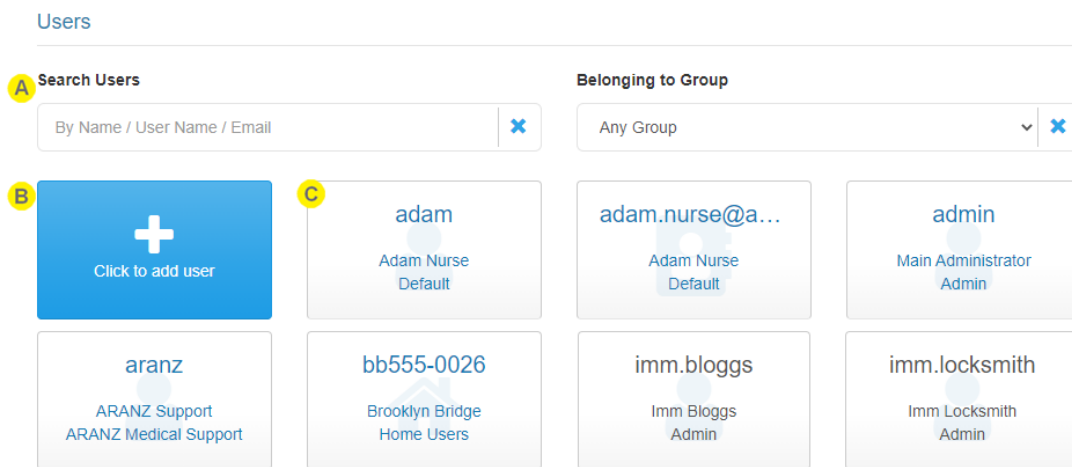

### A Filter options

Limit the users shown in the list using these options.

### B Create button

Select this button to create Silhouette local clinical users. [See Creating a Silhouette Local Clinical User.](#) Other types of user accounts are created in different ways.

### C User tiles

Select the user tile to view or edit the user account. [See Viewing and Editing a User.](#)

Most common tasks for a User manager (e.g. unlock user accounts, reset passwords, or disable user accounts) are performed by finding and selecting the correct user tile and editing it.

The icon on the tile indicates the type of user.

- The tiles with person icons are Silhouette local clinical user accounts.
- The tiles with address book icons are external authentication provider user accounts.
- The tiles with house icons are Silhouette local home user accounts.

Tiles with gray text are user accounts that are in Locked or Disabled status.

## Creating a Silhouette Local Clinical User

To add a new local clinical user account to Silhouette, in the **Users** screen select the **Click to add user** button. The **Create User** screen is displayed, with compulsory fields marked with an asterisk. Enter the required information.





Note that every local user within the organization must have a unique **User Name**.

The **Group** a user is assigned to determines what Silhouette features and patients the user has access to. See [Groups](#) for more information.

When you have entered the user's details, select the **Save** button at the bottom of the screen to save the user's information. After saving you are returned to the [Users](#) screen.

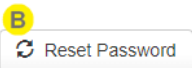
## Viewing and Editing a User

To view user account details (including your own), select that user's tile in the **Users** screen. The information for the user is displayed in a read-only view.

A 
B 
C 
D 
E 

Clinical User Details	
<b>User Name *</b>	<b>Status *</b>
adam	Enabled
<b>Group *</b>	<b>Authentication Provider</b>
Default	Silhouette Local User
<b>First Name *</b>	<b>Middle Name</b>
Adam	-
<b>Last Name *</b>	<b>Phone Number</b>
Nurse	-
<b>Email Address</b>	<b>Last Email Queued</b>
adam.nurse@anonhealth.com	2021-06-25 14:01
<b>Force Password Reset At Next Logon *</b>	
No	

**A** Select **Send Email** to queue a new welcome email from to the user's listed email address. Before the email is queued you will get a chance to review the email content.

The **Send Email** button is only available if there email sending service is configured and enabled and the user account has an **Email Address** configured.

The user details show the **Last Email Queued**, which is the date and time the last welcome email was queued to this user. If a dash (-) is shown that means no welcome email has been sent.

- B** Select **Reset Password** to change the user's password. If the account is your own account then you will be asked to re-enter your own password first.

The **Reset Password** button is only available if the **Authentication Provider** in the user details is listed as Silhouette Local User. Password management for user accounts provisioned for external authentication providers is performed in the external provider.
- C** Select **Delete** to delete a user. A confirmation prompt is presented before the user is deleted.

A user can be disabled instead of deleted by selecting **Edit** and changing the **Status** field. The **Status** drop-down controls if a user can log in to Silhouette. A user is able to log in when their status is "Enabled". To temporarily stop a user from logging in, you can set their status to "Disabled". The status is set to "Locked" if the system has automatically disabled an account due to the incorrect password being entered too many times.

The **Delete** button is only available if the **Authentication Provider** in the user details is listed as Silhouette Local User. User accounts provisioned for external authentication providers are automatically removed from Silhouette after a period of inactivity (nominally after 90 days with no log in) or if they attempt to login and they have had their permission to use Silhouette removed by the external provider.
- D** Select the **Edit** button to change from read-only mode to edit mode.

In Edit mode, compulsory fields are marked with an asterisk. After editing the user's details, select the **Save** button at the bottom of the screen to save the user's information and return you to the read-only view.

The **Edit** button is only available if the **Authentication Provider** in the user details is listed as Silhouette Local User. The user account details for user accounts provisioned for external authentication providers are updated each time that the user logs in to Silhouette. If the user has been disabled in the external authentication provider their account will continue to show with an Enabled status in Silhouette until the account has been deleted due to inactivity.
- E** Select **Close** and to go back to the [Users](#) screen.

## Groups

To ease support burdens, individual user accounts are assigned to groups based upon similar needs with respect to the features and patients they are allowed to access. This allows the permissions to be configured once and applied immediately across a number of user accounts.

As an example, you may create a group to allow data correction tools to be utilized by research staff, while another group containing your clinical staff would not have access to these tools. Groups can also be used to restrict users to interacting with a subset of patients (via units).

To define and manage groups, select **Admin > Groups**. The **Groups** option is not available in SilhouetteConnect when it is running in synchronized mode. In Synchronized mode, group administration is performed in SilhouetteCentral.

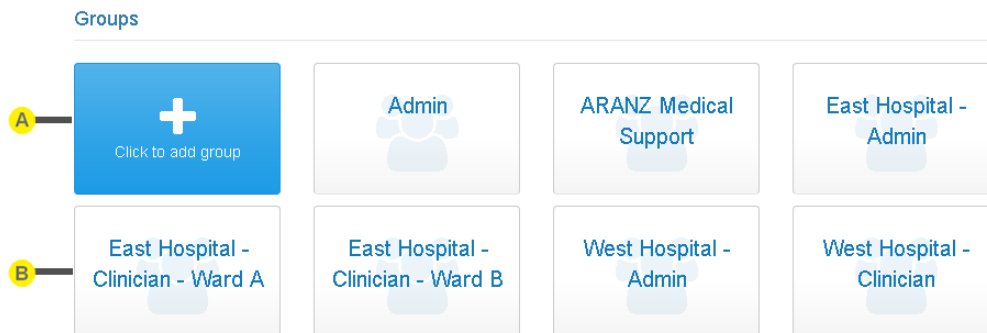

- A** **Create button**  
[See Creating a Group.](#)

- B** **Group tile**  
 Select the group tile to view or edit the group. [See Editing a Group.](#)



## Creating a Group

To create a new group, in the **Group Administration** screen select the **Click to add group** button. The **Create Group** screen is displayed, with compulsory fields marked with an asterisk.

The Save and Cancel buttons are at the bottom of the screen.

Select the **Save** button at the bottom of the screen to create the group.

Select the **Cancel** button at the bottom of the screen to exit the screen without creating the group.

## Group Details

Enter a **Group Name** and **Description**.

The screenshot shows a form titled "Details" with two input fields. The first field is labeled "Name \*" and the second is labeled "Description". Both fields are empty and have a light gray border.

## Group and Unit Relationship

Each group must select which Units that the group permissions apply to in the **For The Following Units** section. The selection of unit limits the patients, users and groups that the group members can access. [See Clinical Groups, Clinical Users, and Units in Silhouette](#) for more information on how the relationship between Users, Patients, Groups and Units work.

The screenshot shows a section titled "For The Following Units" with a list of units and their corresponding "Yes" and "No" buttons. A yellow circle 'A' points to the "All And Future Units" row, and a yellow circle 'B' points to the "East Hospital - Ward A" row.

Unit	Yes	No
All And Future Units	<input type="checkbox"/>	<input type="checkbox"/>
East Hospital - Ward A	<input type="checkbox"/>	<input type="checkbox"/>
East Hospital - Ward B	<input type="checkbox"/>	<input type="checkbox"/>
West Hospital - Ward A	<input type="checkbox"/>	<input type="checkbox"/>
West Hospital - Ward B	<input type="checkbox"/>	<input type="checkbox"/>
West Hospital - Ward C	<input type="checkbox"/>	<input type="checkbox"/>

### **A** All And Future Units

Select Yes for **All And Future Units** to give the group access to all existing units and all new units as they are created within Silhouette.

Select No for **All And Future Units** to manually select which individual units the group has access to.

**B Individual unit selection**

Select which units this group of users has access to.

When a new unit is created in the system then any existing groups do not automatically get permission to access it.

It is possible to create a group that does not have access to any units, however the permissions available to the group will be limited.

**Group Permissions**

Below is a description of each permission that can be assigned to a group. The permissions are divided up into areas:

- Clinical Data Permissions.
- Silhouette Permissions.
- Administrator Permissions.

**Clinical Data Permissions**

Clinical Data Permissions control the access to patient data. A group with no unit access is not allowed access to any clinical data, so none of these permissions will be configurable.

Clinical Data Permissions	
<b>A</b> Can Create Patient Yes	<b>B</b> Can Edit Patient Yes
<b>C</b> Can Delete Patient Yes	
<b>D</b> Can Create Assessment Admission Assessment, SilhouetteLite Assessment, Discharge Assessment, Wound Assessment, Lower Limb Assessment, Visit Assessment	
<b>E</b> Can Edit Assessment Yes	<b>F</b> Can Create Report Yes
<b>G</b> Can Export Data Yes	<b>H</b> Can Delete Assessment Yes
<b>I</b> Can Trace Image Yes	
<b>J</b> Can Create Wound Yes	<b>K</b> Can Edit Wound Yes
<b>L</b> Can Delete Wound Yes	<b>M</b> Can Set Baseline Yes
<b>N</b> Can Link Assessment to Order Yes	<b>O</b> Can Unlink Assessment from Order Yes
<b>P</b> Can Complete Order Yes	

**A Can Create Patient**

Controls if users assigned to this group can create patients.

- B Can Edit Patient**

Controls if users assigned to this group can edit patient details or any of the patient notes.

The ability to view the patient notes in the Clinical UI is also linked to the application the user is using. [See Patient Notes](#) to show how to control which patient notes are visible in each of the Silhouette applications.
- C Can Delete Patient**

Controls if users assigned to this group can delete patients.
- D Can Create Assessment**

Controls which assessments (if any) the user is allowed to create. Creating assessments includes the ability to use images from the portfolio in an assessment (assigns the image to a wound).

This is a multi-selection list box, listing all of the assessment types available in the system. Leaving the selection list empty means that the user can not create any assessments.

The ability to create different assessments is also linked to the application the user is using. [See Assessments](#) to show how to control the assessments that are creatable in each of the Silhouette applications.
- E Can Edit Assessment**

Controls if users assigned to this group can edit assessments. Editing assessments includes the ability to add or remove images.
- F Can Create Report**

Controls if users assigned to this group can create reports for assessments.
- G Can Export Data**

Controls if users assigned to this group can export assessment and patient data to csv files. This permission is only available if the Silhouette license has the Clinical Data Export optional feature enabled.
- H Can Delete Assessment**

Controls if users assigned to this group can delete assessments.
- I Can Trace Image**

Controls if users assigned to this group can add, edit and delete tracings (outlines and rulers) on a captured image.
- J Can Create Wound**

Controls if users assigned to this group can create wounds.
- K Can Edit Wound**

Controls if users assigned to this group can edit wounds.
- L Can Delete Wound**

Controls if users assigned to this group can delete wounds.

- M Can Set Baseline**  
Controls if users assigned to this group can set the baseline for a wound.
- N Can Link Assessment to Order**  
Controls if users assigned to this group can link an assessment to an order.
- O Can Unlink Assessment from Order**  
Controls if users assigned to this group can unlink an assessment from an order.
- P Can Complete Order**  
Control if users assigned to this group can complete orders. Note that the reactivate order permission is granted under Can Manage Orders.



A group with permissions to a unit can view all patients, wounds and assessments for that unit , i.e. there is no separate view permission above.

### Silhouette Permissions

Silhouette Permissions control the access to system functions.

Silhouette Permissions	
<b>A Can Synchronize</b>	<b>B Can Manage Patients</b>
Yes	Yes

- A Can Synchronize**  
Controls if users assigned to this group can synchronize a SilhouetteConnect with SilhouetteCentral.
- B Can Manage Patients**  
Controls if users assigned to this group can add and remove patients from the offline data set held in a SilhouetteConnect install. Groups with **Can Manage Patients** also need **Can Synchronize** permission. A group with no unit access will not be able to have this permission enabled.

### Administrator Permissions

Administrator permissions control access to various sections in the admin sidebar.

Most of the options listed under administrator permissions are only available if the group is set to access **All And Future Units**. The administration permissions that are not available are hidden if **All And Future Units** is set to No. This is because some administrator functionality allows interaction with any patient within the system, or affects all users. See the description of **Can Manage Users and Groups** below.

Administrator Permissions	
<b>A</b> Can Manage Assessment Types	<b>B</b> Can Manage Settings
Yes	Yes
<b>C</b> Can View Logs	<b>D</b> Can Manage Units
Yes	Yes
<b>E</b> Can Manage Users and Groups	
Yes	
<b>F</b> Can Manage Clinical Data	<b>G</b> Can Manage Orders
Yes	Yes

- A Can Manage Assessment Types**  
 Controls if users assigned to this group can edit assessment types.  
 This permission controls the visibility of the **Admin > Assessments** and the **Admin > Patient Notes** items in the Silhouette admin sidebar.
- B Can Manage Settings**  
 Controls if users assigned to this group can access the organization settings.  
 This permission controls the visibility of the **Admin > SilhouetteStar 2** item in the Silhouette admin sidebar.
- C Can View Logs**  
 Controls if users assigned to this group can view the logs.  
*This permission only works for members of the ARANZ Support group.*
- D Can Manage Units**  
 Controls if users assigned to this group can add, edit and delete units.  
 This permission controls the visibility of the **Admin > Units** item in the Silhouette admin sidebar.

### **E** Can Manage Users and Groups

Controls if users assigned to this group can add, edit and delete users and groups.

This permission controls the visibility of the **Admin > Users** and **Admin > Groups** items in the Silhouette admin sidebar.

If a group does not have this permission then the users will have access to **Admin > Profile** to see their own user profile and will be able to change their own password.

The **Can Manage Users and Groups** administrator permission remains available, even when the group does not have access to **All And Future Units**. The scope of this permission is set by the Unit selection for the current group, allowing for the creation of limited administrators.

A limited administrator is a user who can manage users and groups for a limited set of units. A limited administrator is created by assigning a user to a group that has access to a limited set of units and has **Can Manage Users and Groups** enabled. A limited administrator can manage users and groups that have access to the same set (or a subset) of units that the limited administrator has access to. When creating or editing a group, a limited administrator can only select unit(s) for the group that the limited administrator has access to.

### **F** Can Manage Clinical Data

Controls if users assigned to this group can perform clinical data administration tasks.

Clinical administration data tasks include the following:

- Moving images to a different patient.
- Moving assessments to different wounds or patients.
- Changing the date and time recorded for an assessment.

### **G** Can Manage Orders

Controls if users assigned to this group can perform data administration tasks for Orders.



Data administration tasks for Orders include the following:

- Deleting an Order.
- Reactivation of a Completed Order, allowing it to have other assessments linked to it.

## Editing a Group

To edit a group to Silhouette, in the **Group Administration** screen, select the group from the groups list. The information for the group is displayed in a read-only view.

**A**
**B**
**C**

Details			
<b>Name *</b>	<b>Description</b>		
West Hospital - Admin	Administrators for the West Hospital		

For The Following Units			
<b>All And Future Units</b>			
No			
<b>East Hospital - Ward A</b>	<b>East Hospital - Ward B</b>	<b>West Hospital - Ward A</b>	<b>West Hospital - Ward B</b>
No	No	No	No
<b>West Hospital - Ward C</b>			
No			

Clinical Data Permissions		Silhouette Permissions	
<b>Can Create Patient</b>	<b>Can Edit Patient</b>	<b>Can Synchronize</b>	<b>Can Manage Patients</b>
Yes	Yes	Yes	No

### **A** Delete

Select the **Delete** button to delete the group. Before deleting you will be asked to confirm the delete operation.

If a group has users assigned to it, then it can not be deleted.

### **B** Edit

Select the **Edit** button to change to edit mode from read only mode. Update the information, as required. To save the group's settings, select the **Save** button at the bottom of the screen.

A user cannot edit the **Units** and **Can Manage Users and Groups** permission for its own group in order to prevent them from accidentally changing permissions they cannot restore. For example, if user has access to all units and was to change their own group permissions to limited unit access, they would then not be able restore their own permissions to all units as the system would see this as an attempt to escalate their own access to patient data. However, the user change the **Can Create Patient** permission for their own group, as they can always restore that permission.

### **C** Close

Select the **Close** button to go back to the [Groups](#) screen.

## Email Lists

Email lists are only available in SilhouetteCentral and only if the SilhouetteCentral license includes the Assessment Email Actions optional feature.

The Email Lists option allows Silhouette users who need to receive the same Assessment Emails to be grouped into lists. An Email List is a collection of up to 100 Silhouette users who will receive the same email. Emails are sent by defining Assessment Actions and an Assessment Action can reference more than one Email List if the number of recipients for a particular action needs to be higher, see [Creating an Assessment Action](#).

Select **Email Lists** from the admin sidebar to access the feature. **Email Lists** is only available in SilhouetteCentral for users who have the **Can Manage Users** permission and also have access to **All and Future Units**.

### Email Lists



- A** **Add Email List button**  
 See [Creating an Email List](#).

- B** **Email list tile**  
 The tile shows the name of the Email List and the number of users currently in the list.  
 Select the email list tile to view or edit the email list. [See Editing a Group](#).



## Creating an Email List

To create a new Email List, select **Add Email List** in the Email Lists screen. The new email list screen is displayed.

Email List Details

**A** Name \*

**B** Description

Recipients: 2 of 100 (adding 0, removing 0)

**C** Search Users

 ✕

**D** Belonging to Group

 ✕

Recipients **E**

Non Recipients

+ Add All

- Remove All

Name	Email	Staff Group	Status	<b>F</b>
Main Administrator	admin@aranzmedical.com	Admin	Enabled	- Remove
Test User	user1@aranzmedical.com	Admin	Disabled	- Remove

- A** **Name**  
Enter a short name for the Email List.
- B** **Description**  
Enter a longer description for the Email List.
- C** **Search Users**  
Enter some search criteria to filter the list of users presented in both the **Recipients** and **Non Recipients** tabs. The search for users is based on the beginning of their first name, middle name, last name, user name or email address.  
Use the ✕ button to clear the search criteria and to show all users again.
- D** **Belonging to Group**  
Select a staff Group from the drop down to filter the **Recipients** and **Non Recipients** tabs to show only those Users belonging to the selected Group.  
Use the ✕ button to clear the Group filter and show all users again.

## **E** Recipients and Non Recipients tabs

Select the **Recipients** tab to review the list of Silhouette users that are part of Email List and to remove them.

Select the **Non Recipients** tab to review the list of Silhouette users that are not part of the Email List and to add them.

The list of users is split over multiple pages if there are too many to display at once. Paging controls provided at the bottom of the view.

## **F** Add and Remove

Select the **Add** button or **Add all** button to add recipients to the list. The Email List can have a maximum of 100 recipients added to it. The **Add all** button cannot be used if it will cause the Email List to exceed the maximum number of recipients.

Select the **Remove** button or **Remove all** button to remove users from the list.

The **Add all** and **Remove all** buttons add or remove all users shown in all pages of the currently selected tab.

As recipients are added or removed the section header is updated to show the total number in the list. The section header also shows the total number of adds and removes that will be made when the list is saved.

The changes are not saved until the **Save** button is pressed.

The status of the Silhouette user accounts is shown in the list of Recipients. Adding recipients with Disabled or Inactive user accounts is allowed.



Recipients with a status of Disabled will not receive any emails.

Recipients with a status of Inactive and Enabled will receive emails.

## Editing an Email List

Select an Email List tile in the **Email Lists** screen to display an Email List.

Name	Email	Staff Group	Status
Main Administrator	admin@aranzmedical.com	Admin	Enabled
Test User	user1@aranzmedical.com	Admin	Disabled

### A Export

Exports the Email List as a zip file to enable an easier review of the list.

The Export zip file contains two comma separated values (csv) files:

- RecipientGroupEmailActions.csv contains a list of the Assessment Actions that reference this Email List.
- RecipientGroupMembers.csv contains a list of the users in the Email List.

These exports are provided to enable easier review of all recipients and their relationship to Assessment Actions. Changes can not be made in the exported files and then imported.

### B Delete

Deletes the Email List. An Email List can not be deleted if it is used in an Assessment Action.

### C Edit

Opens the Email List in edit mode so users can be added or removed from the list. [See Creating an Email List.](#)

### D Close

Return to the Email Lists administration screen.

**E Search Users and Belonging to Group**

Allows the list of users shown in the **Recipients** and **Non Recipients** tabs to be filtered. [See Creating an Email List](#) for more details.

**F Recipients and Non Recipients tabs**

Select the **Recipients** tab to review the Silhouette users that are part of the Email List.

Select the **Non Recipients** tab to review the Silhouette users that are not part of the Email List.

The list of users is split over multiple pages if there are too many to display at once. Paging controls provided at the bottom of the view.

The status of the Silhouette user accounts is shown in the list of Recipients.



Recipients with a status of Disabled will not receive any emails.

Recipients with a status of Inactive and Enabled will receive emails.

## Assessments

Assessments are the main charting mechanism within Silhouette. Assessments appear on a patient's timeline and represent a set of data recorded at a point in time. Silhouette allows for two different types of assessments:

- Patient Assessments, which are about the patient as a whole (rather than a particular wound) and are useful to record patient risk assessments or similar whole of patient assessments.
- Wound Assessments, which are about a particular wound on the patient and are the main assessment used to track progress of a given wound.

Silhouette comes with some pre-loaded Patient Assessments and Wound Assessments. Extra assessments can be added to the system to suit your organization.

Assessments are different to patient notes, which appear in the patient sidebar and do not relate to a point in time. For example, a patient's allergies may change over time but they are not assessed every week. [See Patient Notes](#) for help administering patient notes.

To define and manage assessments, select **Admin > Assessments**. The **Assessments** option is not available in SilhouetteConnect when it is running in synchronized mode. In Synchronized mode, assessment administration is performed in SilhouetteCentral.

Assessments can also have automatic actions performed when they are created or updated. Assessment actions can be configured for each assessment if your system is licensed appropriately.

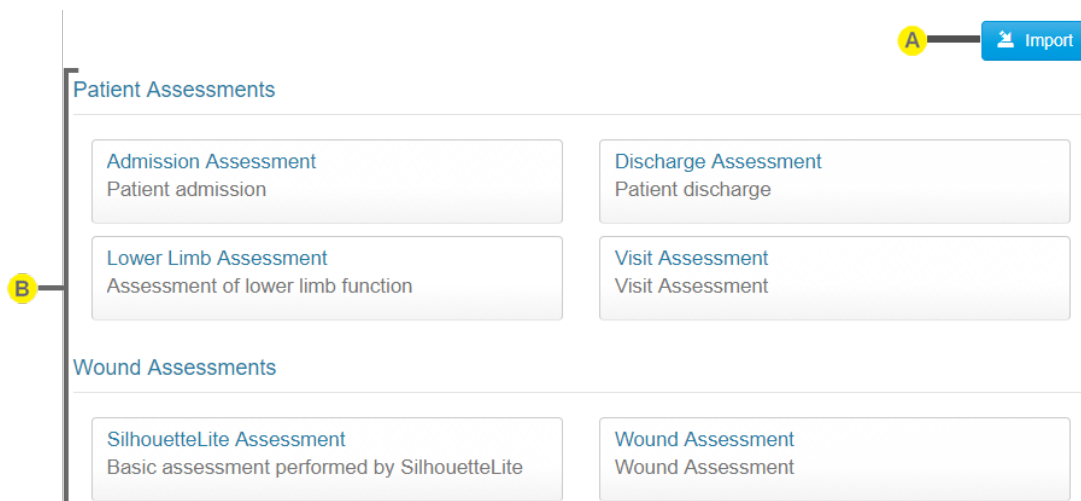

### **A** Import button

Allows an assessment definition zip file to be imported, which either creates a new assessment or modifies the definition of an existing assessment.

A newly imported Assessment is not be accessible to any users by default. [See Editing a Group](#) for information on granting users access to create the new Assessment.

When importing Assessments, the assessment actions and any email templates are also imported. This import may cause additional units or email recipient lists to be created if they don't already exist. The configuration of assessment actions should be reviewed manually after import.

Contact ARANZ Medical Limited for help to configure the assessments you need.

**Assessment Tiles**

Selecting an assessment opens the assessment definition to show the detail and allow editing, [See Editing an Assessment Type](#).



Use caution when modifying the definition of existing assessments. Assessments created offline, in either SilhouetteConnect or SilhouetteLite(+), with previous definitions may fail to sync if the new definition has changes such as making a field required that wasn't previously required.

## Editing an Assessment Type

To edit an assessment in Silhouette, in the **Admin > Assessments** screen, select the assessment from the list. The information for the assessment is displayed in a read-only view.

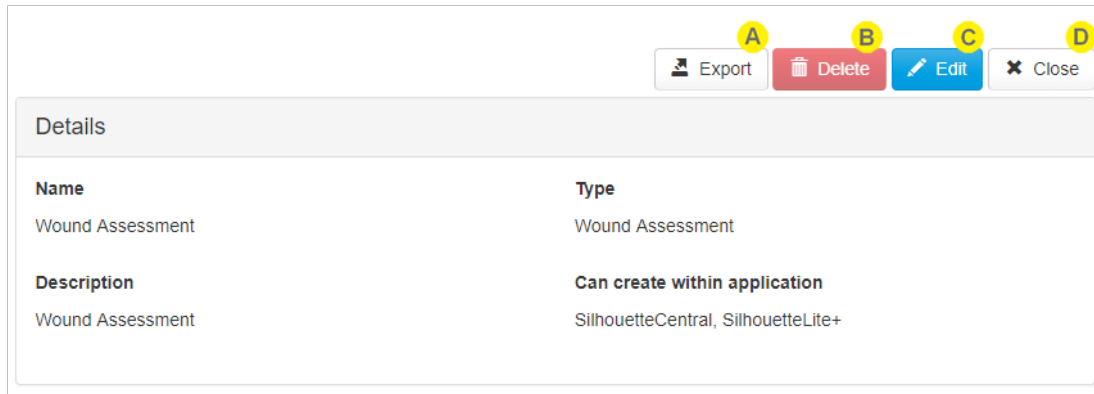

### A Export

Select the **Export** button to download a zip file containing the assessment type definition. The assessment type can then be imported into another Silhouette system (e.g. between a test and production system) or provided to ARANZ Medical for modification.

### B Delete

Select the **Delete** button to delete the assessment type. The system prevents you from deleting assessment types which have been used to create assessments for patients. If you wish to prevent more assessments being created of a given type then disable new assessments by deselecting all applications under the **Can create within application** option.

### C Edit

Select the **Edit** button and update the information as required.

- The **Name** is displayed to users when they create assessments and is displayed at the top of the assessment.
- The **Type** can be Wound Assessment or Patient Assessment.
- The **Description** is provided to show as additional detail to the user when they create the assessment.
- The **Can create within application** allows the selection of which application can be used to create an assessment of this type. Selecting SilhouetteCentral means both SilhouetteCentral and SilhouetteConnect.

Once edited, select the **Save** button at the bottom of the screen to save the settings.

### D Close

Select **Close** to go back to the [Assessments](#) screen.

## Creating an Assessment Action

Assessment actions are only available in SilhouetteCentral and only if the SilhouetteCentral license includes either the Assessment Email Actions or the Silhouette Integration Interface optional features.

Assessment actions available in Silhouette 4.11 are:

- Send Email, which provides the ability to send a list of users an email if an assessment is created or updated, see [Assessment Email](#).
- Send Integration Event, which provides the ability to integrate assessment data with an external system, see [Silhouette Outbound Integration](#).

Each assessment that is created can optionally have many assessment actions. Each assessment action is made up of a trigger (controlling when the action will happen) and the action configuration.

To create or edit an assessment action in SilhouetteCentral, first select the assessment you wish to work with from the list in the **Admin > Assessments** screen. If your system is enabled for Assessment Actions there will be an Assessment Action section available.

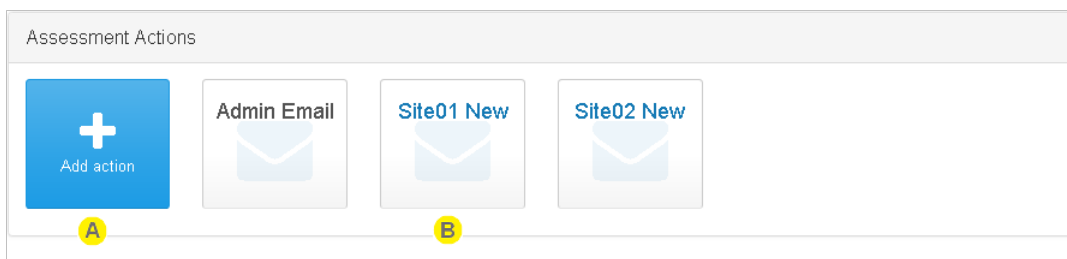

**A** Select the **Add action** button to add a new assessment action.

**B** The assessment actions already created for the assessment are listed as tiles with the assessment action name. Select the assessment action tile to view and edit an existing assessment action.

Disabled assessment actions are shown with gray titles and enabled assessment actions are shown with blue titles.

The tiles have an icon in the background indicating if they are Send Email or Send Integration Event actions.



## Editing an Assessment Action

To edit an assessment action in Silhouette, in the **Admin > Assessments > Assessment** screen, select the assessment action from the list. The information for the assessment action is displayed in a read-only view.

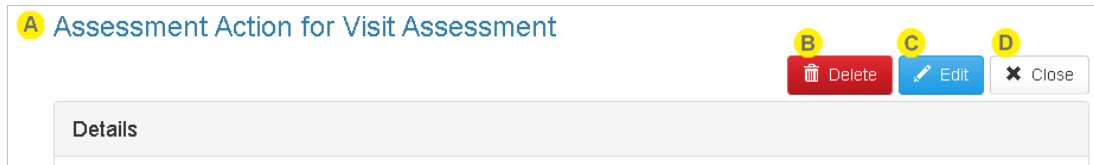

- A** The title of the screen provides information about which assessment type this assessment action is for.
- B** Select the **Delete** button to delete the assessment action.
- C** Select the **Edit** button to switch to edit mode and make changes to the assessment action. See the details below.  
In edit mode there are **Save** and **Cancel** buttons at the bottom of the screen.
- D** Select **Close** to go back to the Assessment screen.

## Assessment Action Details

**Details**

**Name \*** A

**Action Type \*** B

**Enabled** C

Yes
  No

**Description** D

### A Name

Provide a short but descriptive name to help identify the action in the list.

### B Action Type

Select what action be performed when the trigger condition is met. Once the assessment action is saved the **Action Type** can not be changed.

The options are:

- **Send Email** - An email will be queued and sent when the trigger conditions for the assessment action are met.
- **Send Integration Event** - A Silhouette Integration Event will be queued and sent when the trigger conditions for the assessment action are met.

Selecting a value for the action type can cause a change to the information required in the action section before saving the assessment action.

### C Set **Enabled** to Yes to enable the assessment action.

Set **Enabled** to No to disable the assessment action and prevent triggers from occurring.

### D The **Description** field is optional and allows the recording of more details about what the action is intended for. This is helpful for maintenance purposes if there are a lot of actions that have slightly different conditions.

## Trigger Details

**A** Select the assessment **Event**(s) that will cause the action to trigger. The events occur based on the user pressing the **Save** button on the assessment. At least one **Event** must be selected. The available events are:

- **Assessment created**  
Actions including this event will trigger whenever a new assessment of the current type is first saved. Assessments can be created in any of the Silhouette components and this trigger will fire when the assessment gets uploaded (or synced) with SilhouetteCentral.
- **Assessment updated**  
Actions including this event will trigger whenever a user edits and then saves an assessment.

**B** The **In Unit** selection drop down allows you to set this action to trigger only for assessments created or updated for patients in particular units.

- Select **All and future units** to cause the action to trigger on assessments for all patients (i.e. no unit filter).
- Select one or more specific units from the list to restrict the action to only trigger on assessments for patients currently assigned to those units. If a new unit is defined in Silhouette, then assessment actions with a specific **In Unit** filter will need to be edited to include the new unit, if required.

The unit filter for the trigger is evaluated when the trigger is evaluated and does not remember the patient unit when the assessment was actually created or modified.

### Example

Given an assessment action set to trigger for wound assessment created for patients **In Unit** "Site01" and there is a patient "Patient A" in unit "Site01".

The following set of actions will cause the assessment action to trigger:

1. A wound assessment is captured in SilhouetteConnect.
2. The data from SilhouetteConnect is synced to SilhouetteCentral.

However, the following set of action will *not* cause the assessment to trigger:

1. A wound assessment is captured in SilhouetteConnect.
2. The patient is edited so that they are reassigned to unit "Site02".
3. The data from SilhouetteConnect is synced to SilhouetteCentral.



Optionally enter an expression as a **Condition** that must evaluate to true before the assessment action will trigger. [See Appendix H: Conditional Expression Syntax](#) for details on writing expressions.

The expression can use note field variables defined for the assessment or for the encounters and orders. [See Appendix E: Order and Encounter Notes Definitions](#) and "[Appendix E: Order and Encounter Notes Definitions](#)" for the variables defined in the default set of assessment notes. Contact your ARANZ Medical representative for support in creating custom notes fields.

Use the **Validate** button to check the syntax of the entered expression. If the validation is bad then the **Condition** field will turn red.

The condition is evaluated based on the assessment notes values at the time of the trigger evaluation, not at the time the save button was pressed.

#### Example

Given there is a boolean note field "Ready to Email" in wound assessment that has a variable "wound\_ready\_to\_email" and there is an assessment action with a trigger condition of "IsNull(wound\_ready\_to\_email,false) == true".

The following set of actions will cause the assessment action to trigger:

1. A wound assessment is captured in SilhouetteConnect with the value of Ready to Email set to "Yes".
2. The data from SilhouetteConnect is synced to SilhouetteCentral.

However, the following set of action will *not* cause the assessment to trigger:

1. A wound assessment is captured in SilhouetteConnect with the value of Ready to Email set to "Yes".
2. The wound assessment is edited in SilhouetteConnect, changing the value of Ready to Email set to "No".
3. The data from SilhouetteConnect is synced to SilhouetteCentral.

### Action: Send Email Details

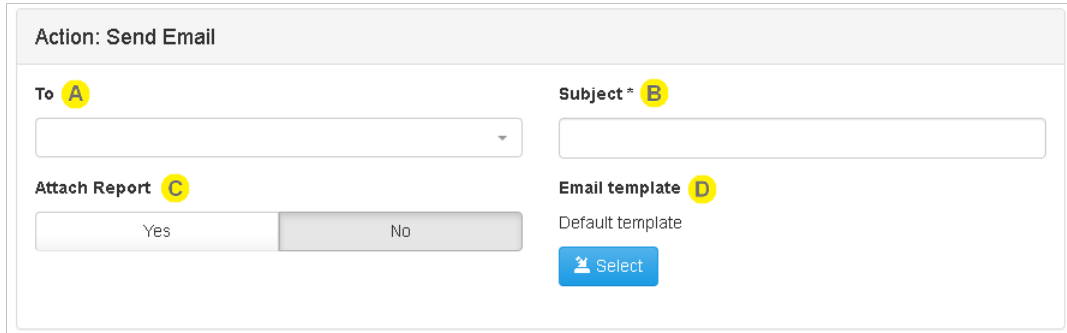

- A** Select one or more Email Recipient Lists in the **To** field.
- B** Enter a **Subject** line for the email.
- C** Set **Attach Report** to Yes to generate and attach a PDF report of the assessment to the email. The PDF reports generated and attached are not encrypted or password protected so consider carefully if patient data privacy can be protected before selecting Yes to **Attach Report**.
- D** The **Email template** sets the content of the email. A default email template is provided and can be downloaded by saving the Assessment Action and selecting the template filename in Edit mode. The default email template provided creates an HTML email in English with no patient data included. The Email body of the default Email template looks like:

A *<assessment type name>* has been created or updated.

Use this link to access the assessment: *<hyperlink to the assessment in SilhouetteCentral>*

[See Appendix J: Email Templates](#) for information on the Email templates. It is recommended contacting your ARANZ Medical representative for support in creating custom Assessment Email templates.

Use the **Select** button to select a new email template.



Consider patient information data privacy when sending emails from Silhouette. If any protected health information or any patient data is included in the email template or by attaching the PDF report then you need to consider any data privacy compliance issues, including processing by email sending providers and email recipient systems.

The default email template doesn't include any patient data and provides a link to SilhouetteCentral, where the recipient must authenticate before viewing the data.

## Action: Send Integration Event Details

**Action: Send Integration Event**

**Report Name Template \*** 



### Report Name Template

Enter the template for the filename using template macros from [Appendix I: Template Macros](#).

Select **Validate** to check the template entered for syntax.

The final formatting of the filename is completed in the downstream integration engine.



Report name template validation may fail if the your permissions to administer assessment types have been removed since you started editing or creating the assessment action. You can test the validation by entering a literal string that will always validate successfully, i.e. filename.pdf.

## Patient Notes

The Patient Notes admin section shows the patient notes categories which appear on the patient sidebar (includes Details, Investigation History, Medical History and Medication by default). Patients notes can be added or removed from the system to suit your organization.

To define and manage Patient Notes, select **Admin > Patient Notes**. The **Patient Notes** option is not available in SilhouetteConnect when it is running in synchronized mode. In Synchronized mode, assessment administration is performed in SilhouetteCentral.

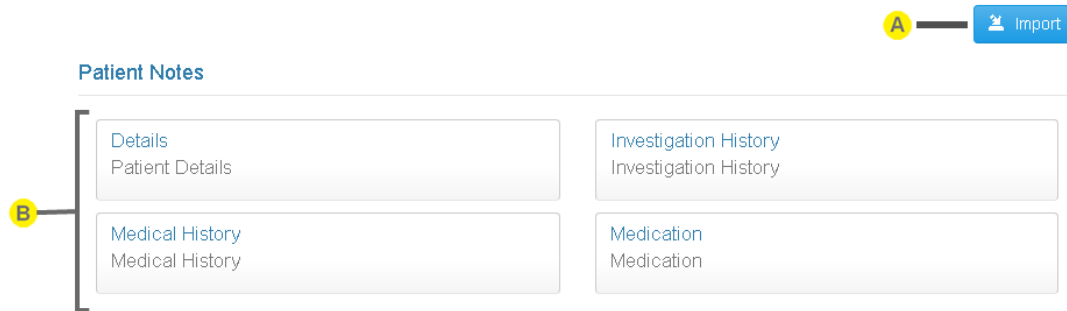

### **A** Import button

Allows patient notes definition zip file to be imported, creating a new patient note or modifying an existing patient notes.

Contact ARANZ Medical Limited for help to configure the Patient Notes you need.

### **B** Patient Note tile

Select the patient note to view and edit the details. [See Editing Patient Notes](#)

## Editing Patient Notes

To edit Patient Notes setup in Silhouette, select the patient note tile from the list of patient notes in the **Admin > Patient Notes**. The information for the patients notes is displayed in a read-only view.

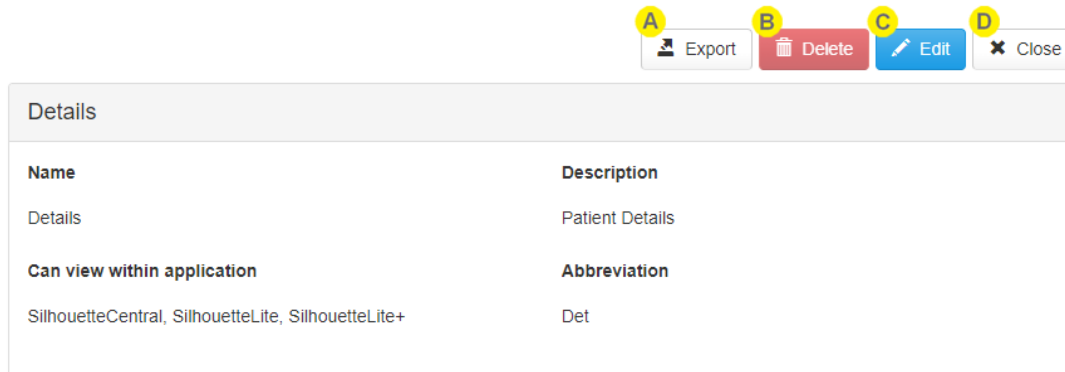

### A Export

Select the **Export** button to download a zip file containing the patient notes definition. The patient notes can then be imported into another Silhouette system (e.g. between a test and production system) or provided to ARANZ Medical for modification.

### B Delete

Select the **Delete** button to delete the patient notes from the system. The system allows you to delete patient notes even if there are some patients with notes recorded against them.

### C Edit

Select the **Edit** button to update the information, as required.

- The **Name** is displayed in the patient sidebar.
- The **Description** allows some text to help keep track of what the patient notes are for.
- The **Can view within application** controls where the patient notes are visible. SilhouetteCentral means both SilhouetteCentral and SilhouetteConnect. Selecting SilhouetteLite or SilhouetteLite+ has no effect as these applications do not have features to view the patient notes.
- The **Abbreviation** is a short string between 1 and 3 characters used to show the patient notes section on the collapsed view of the patient sidebar. The patient details abbreviation is not used as there is a standard icon allocated for use on the sidebar.

Once edited, select the **Save** or **Cancel** button at the bottom of the screen to save or cancel the changes.

### D Close

Select **Close** to go back to the [Patient Notes](#) screen.



## Unit Administration

A unit defines an entity which patients can be assigned to. Different organizations use units in different ways, depending upon how the organization is structured. For example, an organization may use units to differentiate different departments, wards, or facilities.

To define and manage units, select **Admin > Units**. The **Units** option is not available in SilhouetteConnect when it is running in synchronized mode. In Synchronized mode, assessment administration is performed in SilhouetteCentral.

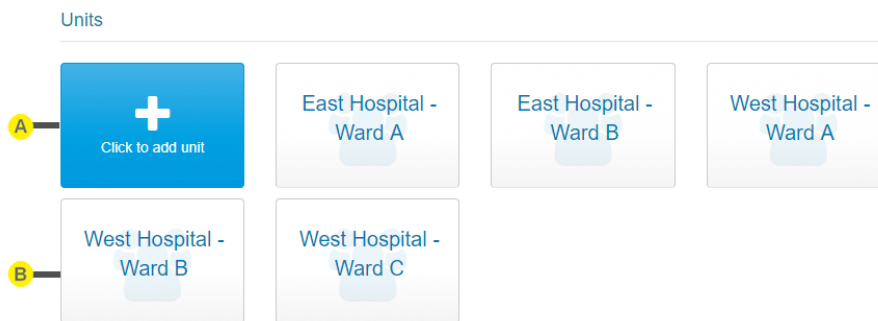

**A** Create button

**B** Unit tile

Select the tile for a unit to view and edit the unit, [See Editing a Unit](#).

## Editing a Unit

To edit a unit in Silhouette, in the **Unit Administration** screen, select the unit from the units list. The information for the unit is displayed in a read-only view.

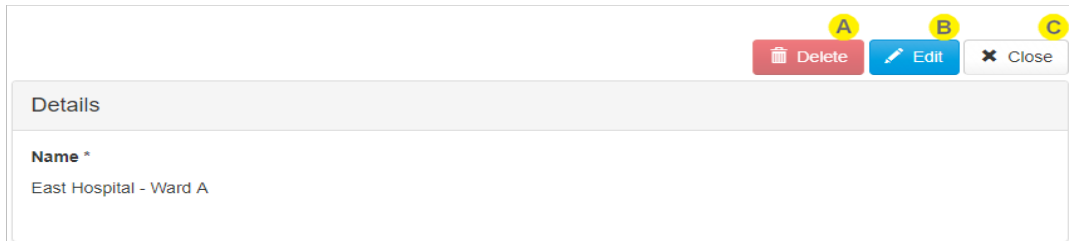

### A Delete

To delete the unit, use the **Delete** button.

Silhouette does not allow all units to be deleted.

Silhouette prevents a unit with patients assigned to it from being deleted.

### B Edit

Select the Edit button to change from ready-only view to editing mode.

- The **name** is used through-out the system to represent the Unit, including when creating and editing patients.

Once edited, select the **Save** or **Cancel** button at the bottom of the screen to save or cancel the changes.

### C Close

Select **Close** to go back to the [Unit Administration](#) screen.

## SilhouetteStar 2

The SilhouetteStar 2 settings available depend on if you are using the device in wired USB mode with SilhouetteConnect or in Wi-Fi mode with SilhouetteCentral.

- Wired mode with SilhouetteConnect has options for [SilhouetteStar 2 DHCP Configuration](#).
- Wi-Fi mode with SilhouetteCentral has options for [Network Configurations and Wireless Camera Tools](#).

### SilhouetteStar 2 DHCP Configuration

When operating with SilhouetteConnect in wired USB mode, the SilhouetteStar 2 establishes a network connection with the computer using an Internet Protocol (IP) address. The SilhouetteStar 2 device provides the computer an IP address via the Dynamic Host Configuration Protocol (DHCP). The default IP address used by the SilhouetteStar 2 is 169.254.0.1 /30 and it assigns the address 169.254.0.2 /30 to the computer.

In some rare cases the default network used may not be suitable in the organization. In these cases a fixed network will need to be assigned for use by all SilhouetteStar 2 devices. The **Admin > SilhouetteStar 2** page provides SilhouetteStar 2 DHCP Configuration settings. These settings are available in SilhouetteConnect in both synchronized and standalone operational modes.

**SilhouetteStar 2 DHCP Configuration**

---

**Computer IP Address \***

**A**

**SilhouetteStar 2 IP Address \***

**B**

**Subnet Mask \***

**C**

**D**

#### **A** Computer IP Address

Enter the IPv4 Address (in dotted decimal notation) that the SilhouetteStar 2 device should assign to the computer. This address must be in the same IPv4 subnet as the SilhouetteStar 2 IP Address, with respect to the Subnet Mask.

The default factory setting is 169.254.0.1

#### **B** SilhouetteStar 2 IP Address

Enter the IPv4 Address (in dotted decimal notation) that the SilhouetteStar 2 device will use. This address must be in the same IPv4 subnet as the Computer IP Address, with respect to the Subnet Mask.

The default factory setting is 169.254.0.2

#### **C** Subnet Mask

Enter the IPv4 Subnet Mask (in dotted decimal notation) for the SilhouetteStar 2 / Computer link network. This Subnet Mask must allow the network to span the Computer IP Address and the SilhouetteStar 2 IP Address.

The default factory setting is 255.255.255.252

## D Generate QR Code

Once valid IP addresses have been entered, click on the **Generate QR Code** button. A QR Code encoding the settings is displayed on the screen.

The screenshot shows a web interface for configuring a SilhouetteStar 2 device. On the left, under the heading "SilhouetteStar 2 DHCP Configuration", there are three input fields: "Computer IP Address \*" with the value "169.254.0.2", "SilhouetteStar 2 IP Address \*" with the value "169.254.0.1", and "Subnet Mask \*" with the value "255.255.255.252". Below these fields is a blue button labeled "Generate QR Code". On the right, under the heading "Generated QR Code", a square QR code is displayed.

### Apply the Settings to SilhouetteStar 2

To apply the settings to the SilhouetteStar 2:

- With the device turned on and not connected to Silhouette (displaying *Please Connect*),
- Press the device button to turn on the lasers (begins scanning for a QR Code),
- Hold the device up to the screen with the button at the top and so that the lasers form a star over the QR code,
- The device will display "DHCP Updated" once the QR Code has been scanned and the settings have been saved.
- To apply the settings, reset the device by holding the device button down for approximately 16 seconds. The screen will go blank and the button can needs to be pressed again to start the device.

Once these settings are applied to a device, they are remembered even when the device firmware is updated.

The QR code can be printed and used to set all your SilhouetteStar 2 devices to the same settings. There is no need to generate a new QR code each time. The QR code in the example diagram above can be used to set the SilhouetteStar 2 back to default settings.

## Checking the SilhouetteStar 2 DHCP Configuration

To confirm the DHCP settings the SilhouetteStar 2 is using, you can check the settings once the device is plugged into a PC by:

- Navigating to the Control Panel > Network and Internet > Network Connections.
- Right-click on the Ethernet Adapter that has a SilhouetteStar 2 label and selecting **Status**.
- On the Ethernet Adapter status page click the **Details...** button.
- The IPv4 Address, IPv4 Subnet Mask and IPv4 DHCP Server are all listed in the Network Connection Details dialog and correspond to the Computer IP Address, the Subnet Mask, and the SilhouetteStar 2 IP Address settings in Silhouette.

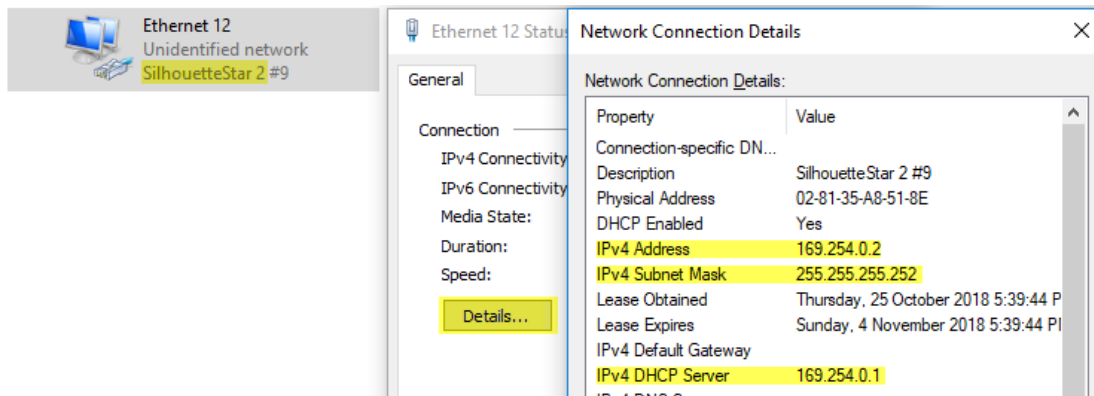

## Network Configurations and Wireless Camera Tools

The settings in the **SilhouetteStar 2** screen are used to allow the SilhouetteStar 2 device to connect to the organization's Wi-Fi network.

These Wi-Fi networks are displayed within SilhouetteCentral in the connection QR code, which the device uses to read the network settings and connect to a users web session.

To define and manage network configurations, or to access the wireless camera tools, select **Admin > SilhouetteStar 2** in SilhouetteCentral. The **Network Configurations** and **Wireless Camera Tools** sections are not available in SilhouetteConnect.

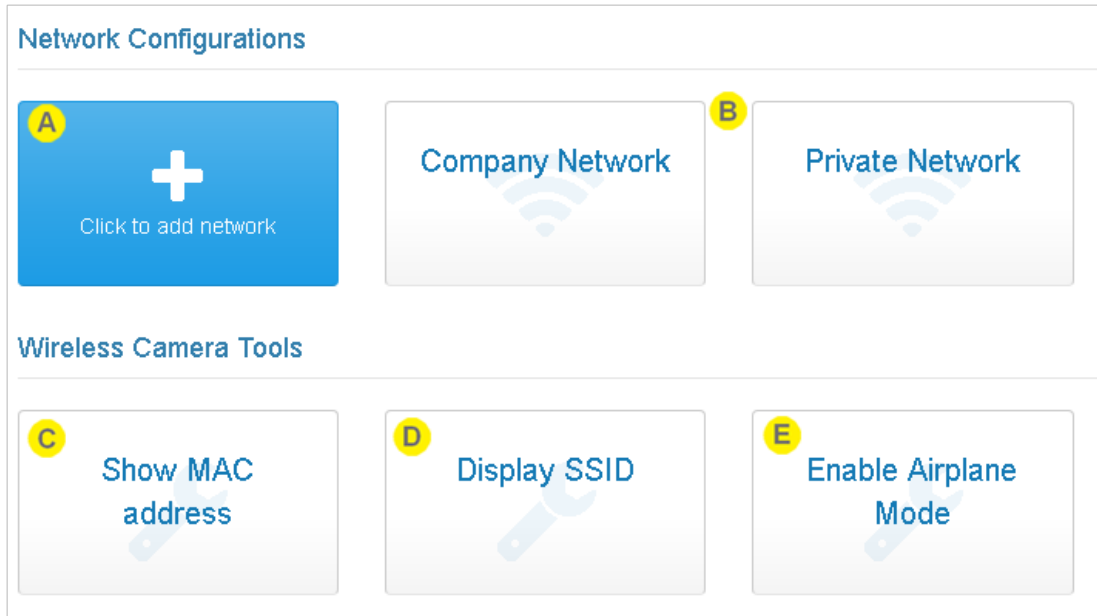

**A** **Create button**  
[See Creating a Network Configuration.](#)

**B** **Network Configuration tile**  
[See Editing a Network Configuration.](#)

**C** **Show MAC Address**  
 Select **Show MAC address** to show a QR code that can be scanned by a SilhouetteStar 2 device to show the Wi-Fi MAC address of the device on its display.

Once scanned, the device shows the Wi-Fi MAC address until it is dismissed with a device button press.

**D** Display SSID

To confirm the SilhouetteStar 2 is attempting to connect to the correct Wi-Fi network, select **Display SSID** to show a QR code that can be scanned by a SilhouetteStar 2 device to cause the Wi-Fi network SSID to be displayed on the device screen.

The SSID is shown on the third line of the display, replacing the Patient DoB. The SSID of the Wi-Fi network is displayed whenever the device is connected to Silhouette, or if it is attempting to connect to a Wi-Fi network.

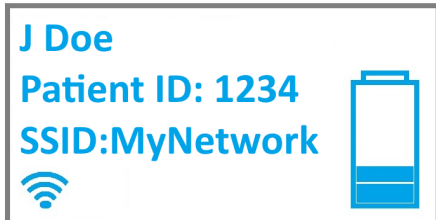

The SilhouetteStar 2 device continues show the SSID on the display until it is power cycled or until the **Display SSID** QR code is scanned again.

**E** Enable Airplane Mode

To turn off the Wi-Fi capabilities of the SilhouetteStar 2 select Enable Airplane Mode and use the SilhouetteStar 2 to scan the displayed barcode.

Once airplane mode is successfully enabled the SilhouetteStar 2 device shows the airplane icon in place of the Wi-Fi signal strength indicator.

To enable Wi-Fi again follow the normal SilhouetteStar 2 connection process.



The Wireless Camera Tools QR codes can only be scanned if the SilhouetteStar 2 is not already connected to a network.



The Wireless Camera Tools QR codes can be printed, or downloaded as images and emailed. This may help if you need Silhouette users without admin access to scan them for diagnostic or setup purposes.

## Creating a Network Configuration

Select the **Click to add network** button in the **SilhouetteStar 2** screen to create a new network configuration. The **Create Network** screen is displayed, with compulsory fields marked with an asterisk.

Enter a **Name**, **Type**, **Network SSID**, and **Network Password**. The network password must be at least 8 characters long.

To save the network settings, select the **Save** button at the bottom of the screen.

## Editing a Network Configuration

To edit a network configuration, in the **SilhouetteStar 2** screen, select the network from the networks list. The information for the network is displayed in a read-only view.

Select the **Edit** button to edit the network and update the information, see [Creating a Network Configuration](#).

To delete the network, use the **Delete** button.



Select the **Close** button to go back to the [Network Configurations and Wireless Camera Tools](#) screen.

## Retrieving SilhouetteStar 2 Device Logs

The SilhouetteStar 2 device keeps software logs, which can be accessed and sent to ARANZ Medical support if there are any problems with the SilhouetteStar 2.

The logs are able to be downloaded from a basic web site hosted on the SilhouetteStar 2. To access the web site:

1. Have the SilhouetteStar 2 turned on and plugged into the computer using the USB cable.
2. Use a Web Browser on the computer to access the web page at <http://169.254.0.1/>. [See Checking the SilhouetteStar 2 DHCP Configuration](#) to confirm the IP address that the SilhouetteStar 2 is using.

An example of the SilhouetteStar 2 device web site is shown below in the IE web browser.

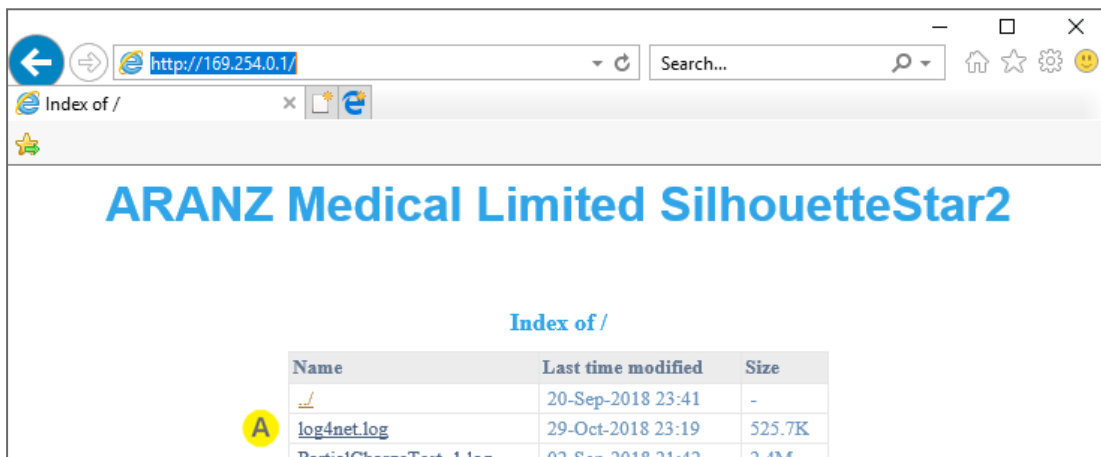

### **A** log4net.log

The log file(s) on the SilhouetteStar 2 device have the file name **log4net.log**.

To download a log file right-click on the file name and select *Save link as....* If you need to supply log files to ARANZ Medical Support:

1. Save the file(s) to your local computer into a folder named with the device serial number and the current date.
2. Zip the whole folder up.
3. Send the zipped log file folder to [support@aranzmedical.com](mailto:support@aranzmedical.com).

The SilhouetteStar 2 creates a new log file once the current log file reaches a size limit (nominally 1MB) and archives the older log files. Up to 10 older log files are kept on the device before being deleted.

- The current log file on the device is named log4net.log.
- The most recent archived log file is named log4net.log.1
- The oldest archived log file is named log4net.log.10.

There may be other files available for download but these can typically be ignored.

## License

The **Admin > License** screen allows you to update the license for the current Silhouette component. For example, the **License** screen in SilhouetteCentral shows details about the licensing of SilhouetteCentral and the **License** screen in SilhouetteConnect shows details about the licensing for that install of SilhouetteConnect. The following license details are displayed:

1. **Client Code:** The client code that the product is licensed against. If there is no client code in the text box, then the Silhouette instance is unlicensed and operating in a trial mode.
2. **Created:** The creation date of your license.
3. **Expires:** This is the expiry date of your license. The word 'Never' is displayed if you have a perpetual license.
4. **Features:** Any optional software features that have been enabled with the license are listed here. [See Licensed Features](#) for information on the optional features available.

## Licensing Silhouette

A **Check for Update** section with an **Update** button is provided below the license details. To license Silhouette for the first time, enter your client code and select the **Update** button. To subsequently update your license, for example if you have purchased additional features or extended your warranty, it is only necessary to select the **Update** button.

In order for the automatic license update process to function, access to the Internet is required. If there is no Internet access, instructions on obtaining the license file manually are provided once the **Update** button is pressed.

### HTTP Proxy Configuration

The ARANZ Medical licensing server is hosted on the internet. When attempting communication with the licensing server, SilhouetteCentral uses .NET's default proxy settings. If your network environment requires the use of a different proxy server, update the defaultProxy setting within the SilhouetteCentral web.config file.

As an example if you desire SilhouetteCentral to make use of a proxy server located at 192.168.2.1 port 8888 you could update the relevant section of the web.config file as follows:



```
<system.net>
  <defaultProxy enabled="true">
    <proxy proxyaddress="http://192.168.2.1:8888"/>
  </defaultProxy>
</system.net>
```

Please refer to Microsoft's online .NET framework configuration documentation for further details.

## Email Configuration

The email configuration page contains both the email sending SMTP settings as well as some details as to the current state of the email system within Silhouette.

### SMTP Configuration

The Email Configuration options must be enabled to allow certain system functions to operate, e.g. password reset, and can only be set in SilhouetteCentral.

Select the Email Configuration option in the admin sidebar to set the SMTP Email server settings.

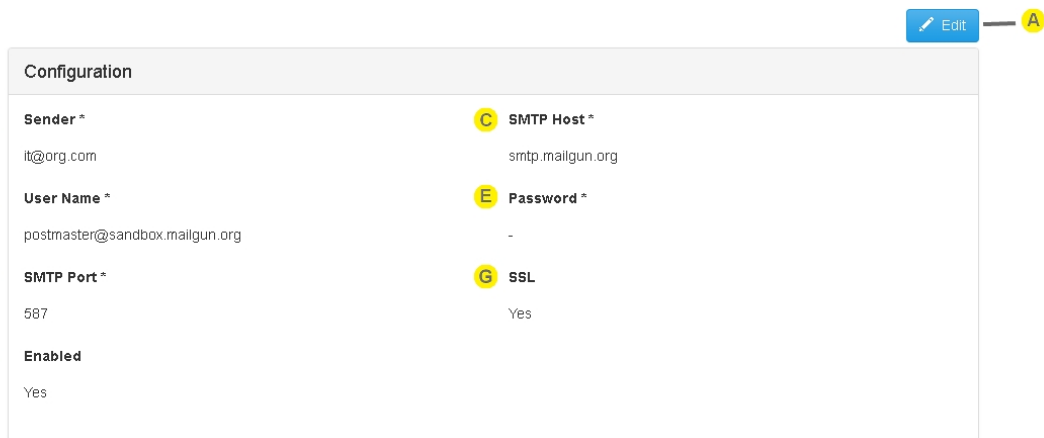

Configuration	
<b>B</b> Sender *	lt@org.com
<b>D</b> User Name *	postmaster@sandbox.mailgun.org
<b>F</b> SMTP Port *	587
<b>H</b> Enabled	Yes
<b>C</b> SMTP Host *	smtp.mailgun.org
<b>E</b> Password *	-
<b>G</b> SSL	Yes

**A**

#### Edit

Select the **Edit** button to change from read-only mode to edit mode.

In Edit mode, compulsory fields are marked with an asterisk. After editing the Email configuration details, select the **Save** button at the bottom of the screen to save the configuration and return to the read-only view.

The Edit button will not be present for SilhouetteCentral instances hosted by ARANZ Medical, as these instances have their email settings managed by ARANZ Medical. Please contact your Account Manager if you are a hosted SilhouetteCentral customer and wish to customize your email configuration.

**B**

#### Sender

The reply to address used when sending email from Silhouette.

**C**

#### SMTP Host

The Simple Mail Transfer Protocol (SMTP) host that is used to send Email.

**D**

#### User Name

The user name of the account used to send mail on the SMTP host.

**E**

#### Password

The password of the account used to send mail on the SMTP host.

**F**

**SMTP Port**

The TCP port used to communicate with the SMTP host. Get this information from the SMTP host provider.

**G**

**SSL**

Set to Yes if your SMTP Host supports sending Email using SSL.

**H**

**Enabled**

Set to Yes to enable Email sending from SilhouetteCentral.  
Set to No to disable all Email sending from SilhouetteCentral.

**Welcome Email**

To edit the Welcome Email template select the Edit button at the top of the page.

The default templates provided with Silhouette include placeholder text that is not suitable for sending to users. They are provided as a starting point. As a minimum the following changes should be made:

- Replace the text *(Insert Organisation Name)* with your organizations name.
- Replace the text *(Insert URL here)* in the Home User template with a link to your privacy policy or statement.
- Consider adding any helpful getting started instructions, letting users know why they are receiving the email and giving them a contact address if they have any questions.
- If you wish to share any terms or conditions of use with the users then the welcome email is a good place to include these (or a link to them).



Welcome Email	
<b>Clinical User Email Subject *</b> Welcome to Silhouette	<b>Clinical User Email Template</b> <a href="#">DefaultClinicalTemplate.cshhtml</a>
<b>Home User Email Subject *</b> Welcome to Silhouette	<b>Home User Email Template</b> <a href="#">DefaultHomeTemplate.cshhtml</a>

**A**

**Email Subjects**

The email subject line for any welcome emails sent from Silhouette.

If the Home User Access feature is enabled then there are separate email subject configuration for the Clinical vs. the Home users.

## B Email Templates

The email template dictates what is included in the body of the welcome emails.

If the Home User Access feature is enabled then there are separate email template for the Clinical vs. the Home users.

In read mode, select the link to download the current template file. This file can be edited with help from ARANZ Medical support.

In edit mode, a valid welcome email template file can be selected and uploaded with your custom template, see [Appendix J: Email Templates](#).

## Email System Statistics

At the bottom of the Email Configuration page, there is a section showing the performance of the email system.

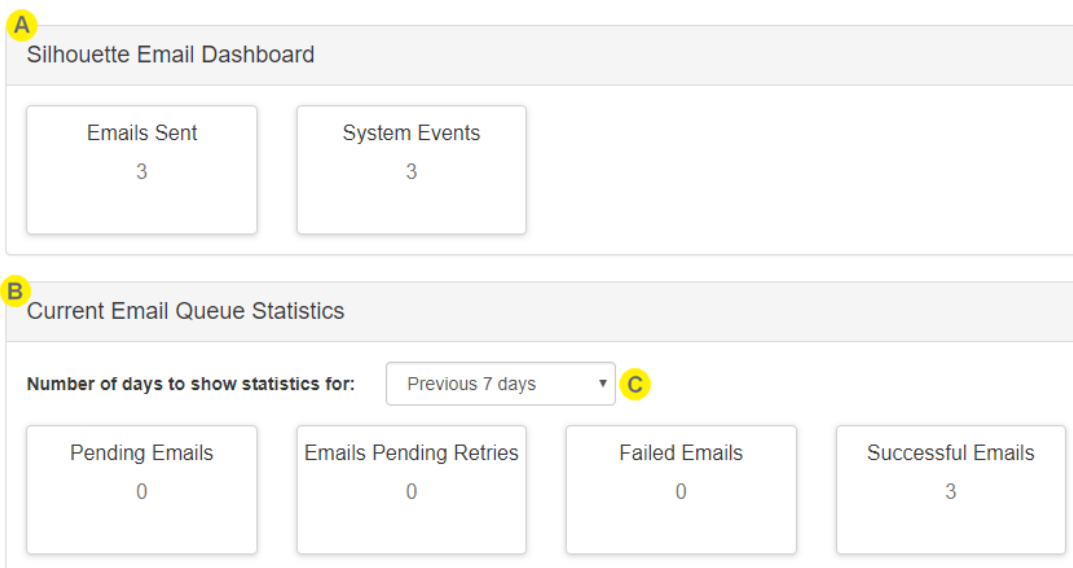

## A System Email Dashboard

This section shows the total number of emails sent and system events (e.g. assessment create or update events) that caused an email that have ever been generated by Silhouette. Typically the email sent count will be higher as a single system event can result in multiple emails generated with each email getting sent to multiple recipients as individual emails.

## B Current Email Queue Statistics

This section shows the count of emails in the current processing queue. The queue only shows values for up to a maximum of 30 days, as the emails that have been sent by Silhouette that are older than this are removed from the System.

**Pending Emails:** The number of emails that are in the queue waiting to be sent

**Emails Pending Retries:** The number of emails that have failed to send at least once, but that Silhouette will attempt to send later

**Failed Emails:** The number of emails that have failed to send even after Silhouette has tried multiple times to send them.

**Successful Emails:** The number of emails that successfully been sent.



**Current Email Queue Statistics Date Range**

Select the date range to show the current queue statistics for.

## Anatomical Sites

The **Anatomical Sites** page allows you to review and enter codes for each of the anatomical sites within Silhouette for the purposes of integration.

The codes are made available for use when integrating data out of Silhouette into an external system. Coding data into Silhouette from an external system must be achieved in a data transformation prior to reaching the Silhouette Integration Interface.



The Anatomical Sites page does not allow the editing of the anatomical site hierarchy. To modify the anatomical site hierarchy used in Silhouette please contact [support@aranzmedical.com](mailto:support@aranzmedical.com).

The full anatomical site hierarchy setup in Silhouette is shown in [Appendix B: Anatomical Site Hierarchy](#).

Select **Anatomical Sites** from the admin sidebar to show a list of the Anatomical Groups in the system.

### Anatomical Groups

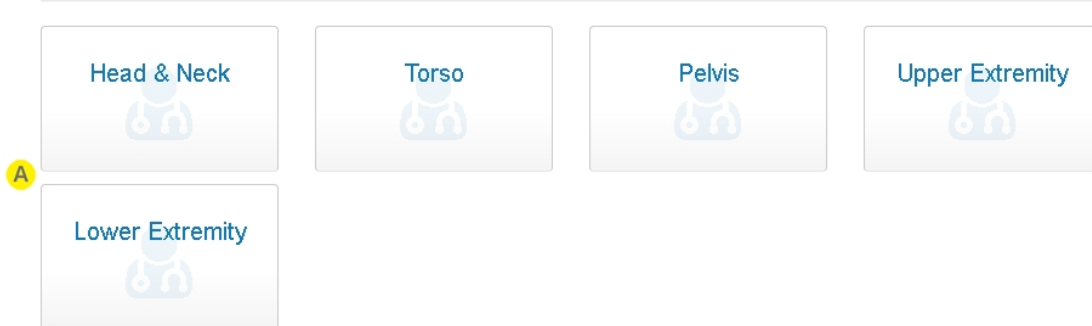



Select an Anatomical Group tile to view the anatomical sites within that group as a table, see [Anatomical Site Codes](#).

## Anatomical Site Codes

The **Anatomical Sites** page allows you to review and enter codes for each of the anatomical sites within an Anatomical Group.

- Empty cells in the Handedness and Region columns of the table indicate that there is no grouping at that level of the anatomical hierarchy.
- An unspecified Code value is shown as a '-'.

**A**  Edit
**B**  Close

Details				
Gross Division	Handedness	Region	Display Text	Code
Scalp		Superior	Scalp, Superior	-
Scalp		Posterior	Scalp, Posterior	-
Scalp		Left Lateral	Scalp, Left Lateral	-
Scalp		Right Lateral	Scalp, Right Lateral	-
Forehead		Anterior	Forehead, Anterior	-
Forehead		Left Lateral	Forehead, Left Lateral	-
Forehead		Right Lateral	Forehead, Right Lateral	-
Temple	Left		Left Temple	-
Temple	Right		Right Temple	-
Orbit	Left	Superior	Left Orbit, Superior	-
Orbit	Left	Inferior	Left Orbit, Inferior	-

### **A** Edit

Select **Edit** to change the **Code** for each anatomical site, see [Editing Anatomical Site Codes](#).

### **B** Close

Select **Close** to go back to the list of Anatomical Groups.



## Editing Anatomical Site Codes

Details				
Gross Division	Handedness	Region	Display Text	Code
Scalp		Superior	Scalp, Superior	<input type="text"/>
Scalp		Posterior	Scalp, Posterior	<input type="text"/>
Scalp		Left Lateral	Scalp, Left Lateral	<input type="text"/>
Scalp		Right Lateral	Scalp, Right Lateral	<input type="text"/>
⋮				
Neck		Posterior	Neck, Posterior	<input type="text"/>

**B** 
**C**

- A

**Enter a short code into the **Code** column for all sites that need a code for integration.**

The use of duplicate codes is allowed so that sites can be grouped as a common item for integration purposes.

The codes entered can be up to 128 characters but it is recommended to keep them much shorter than that.
- B

**Save**

Select **Save** to save the changes to the codes.
- C

**Cancel**

Select **Cancel** to exit edit mode without saving the changes to the codes.

## Silhouette Configuration

The **Silhouette Configuration** page contains configuration items that change the Silhouette system operation. The configuration items are organized into sections and each section may or may not be available depending on the application you are accessing (SilhouetteCentral or SilhouetteConnect) and the optional features that are included in the license.

Select the **Edit** button to edit any of the settings.

When editing, a **Save** and **Cancel** button is available at the bottom of the screen.

- Select **Save** and apply all configuration changes.
- Select **Cancel** to discard changes.

## Automatic Boundary Detection

**Automatic Boundary Detection**

Enabled A

Yes

No

### A Enabled

The automatic wound boundary detection feature reduces the time taken to trace wounds by allowing clinicians to define a region of interest (ROI) on the image and then instruct Silhouette to automatically detect the wound boundary within the ROI. The automatic wound boundary detection algorithm works best when used on wounds with well defined boundaries (e.g. typical diabetic foot ulcers).

The automatic wound boundary detection feature does not replace a clinician's judgment. A clinician with appropriate expertise is still required to review and edit the auto outline before accepting it. The more complex the wound boundary the more likely the user will need to manually edit the automatic boundary or revert to manually tracing the image.

- Select **Yes** to enable all users to use the Auto Boundary Detection tool when tracing images.
- Select **No** to disable the use of the Auto Boundary Detection tool for all users.

This setting is available in SilhouetteCentral and in SilhouetteConnect when operating in Standalone mode.

## Outbound Integration

The outbound integration configuration options are only available in SilhouetteCentral and only if SilhouetteCentral has the Silhouette Integration Interface licensed.

Outbound Integration	
<b>A Enabled</b>	Yes
<b>B Uri *</b>	http://staging.aml
<b>C Port *</b>	9999
<b>D Authentication Type *</b>	Basic
<b>User Name *</b>	silhouettesystem
<b>Password *</b>	-

### A Enabled

Select **Yes** to allow SilhouetteCentral to send integration events to the downstream integration engine. Select **No** to stop SilhouetteCentral sending integration events to the downstream integration engine.

When outbound integration is enabled, users creating or updating assessments can cause an outbound integration event to be sent to the downstream integration engine (see the topic [Silhouette Outbound Integration](#) for more details).

Disabling outbound integration stops integration events being sent, rather than delaying them to be sent later. If outbound integration is enabled again, only new actions are processed causing outbound integration events.

### B Url

Enter the Url of the integration engine to send the integration events to.

The entered Url should begin the protocol `http://` or `https://` and a hostname. A path after the hostname is not supported. Examples:

- `https://integrationengine.domain`
- `http://localhost`
- `http://10.10.10.10`

### C Port

Enter the TCP port number to match the integration engine HTTP listener TCP Port.

### D Authentication Type

Set the authentication type to Basic for Basic HTTP Authentication or None for no Authentication.

If the authentication type is set to Basic, specify a User Name and Password as required by the integration engine configuration.

## Inbound Integration

The inbound integration configuration options are only available in SilhouetteCentral and only if it has the Silhouette Integration Interface licensed.

**Inbound Integration**

**A** Create record on update request if record not found

Yes

**B** Encounter Integration Model Order Integration Model

[Download](#) [Download](#)

Patient Integration Model Merge Patients Integration Model

[Download](#) [Download](#)

### A Create record on update request if record not found

The Silhouette inbound integration interface supports separate 'create' and 'update' requests but can allow 'update' requests to be used for both update and create.

Select **Yes** to cause SilhouetteCentral to create a record when an update request is received and the record does not already exist.

Select **No** to cause SilhouetteCentral to send an error response to the update request if an update request for a record that does not already exist.

This setting applies to all entities on the integration interface (e.g. patients, encounters, and orders).



It is recommended that this setting is enabled unless there is a requirement to treat updates and creates differently.

### B Integration Models

Use the **Download** links to download the currently configured Silhouette integration data models. These models are updated when the notes configuration in Silhouette change. The XML data models downloaded using these links are used in the integration engine when mapping external data formats into the Silhouette data models.

There is an integration model for each endpoint on the Silhouette Integration Interface and for each Assessment Type within Silhouette. The Silhouette integration interface expects that incoming data conforms to the appropriate Silhouette Integration Model.

## Appendices



[Appendix A: Getting Support](#)



[Appendix B: Anatomical Site Hierarchy](#)



[Appendix C: Wound State Definitions](#)



[Appendix D: Notes Definitions](#)



[Appendix E: Order and Encounter Notes Definitions](#)



[Appendix F: Clinical Data Export Format](#)



[Appendix G: Regular Expressions](#)



[Appendix H: Conditional Expression Syntax](#)



[Appendix I: Template Macros](#)



[Appendix J: Email Templates](#)

## Appendix A: Getting Support

You can contact ARANZ Medical support by using the contact information listed below:

### Customer Support

Email: [support@aranzmedical.com](mailto:support@aranzmedical.com)

Phone (International): +64 3 961 1988

Phone (US Customers): 855 272 0341

Phone (UK Customers): 0800 011 9628

### Sales Inquiries

Phone (International): +64-3-374-6120

Phone (US customers): 866-467-0934

Fax: +64-3-374-6130

Email: [sales@aranzmedical.com](mailto:sales@aranzmedical.com)

Please contact your system administrator for first level support contact information.

### ARANZ Medical Website

[www.aranzmedical.com](http://www.aranzmedical.com)

## Appendix B: Anatomical Site Hierarchy

Wounds recorded within SilhouetteConnect and SilhouetteCentral are always assigned to an anatomical site for grouping, reporting and identification purposes.

The anatomical sites in Silhouette are organized into a hierarchy with the following levels:

- Group. All anatomical sites are contained within a top level group.
- Gross Division. The gross division level always exists in the hierarchy and is used to identify a broad area of anatomy.
- Handedness. Some anatomical sites have a handedness, e.g. left or right.
- Region. The region level is used if the gross division is too gross and needs further division into regions.

When specifying an anatomical site the user is prompted to select options from each level in the hierarchy, from the Group to the Region level. The options available in the next level depend upon the selection the user made in the previous.

The anatomical sites described in this appendix reflect the default set of anatomical sites setup within SilhouetteCentral and SilhouetteConnect. They do not show any customizations made.

- The Display Text is the anatomical site description used within Silhouette. It typically uses an algorithmic approach to combine the various levels of the hierarchy into a description. In a few cases the algorithm generated description is overridden by a specific location description.
- The Code can be configured in Silhouette to be used alongside the description when sending data to another IT system.

### Head & Neck

Gross Division	Handedness	Region	Display Text	Code
Scalp		Superior	Scalp, Superior	
		Posterior	Scalp, Posterior	
		Left Lateral	Scalp, Left Lateral	
		Right Lateral	Scalp, Right Lateral	
Forehead		Anterior	Forehead, Anterior	
		Left Lateral	Forehead, Left Lateral	
		Right Lateral	Forehead, Right Lateral	
Temple	Left		Left Temple	
	Right		Right Temple	

Gross Division	Handedness	Region	Display Text	Code
Orbit	Left	Superior	Left Orbit, Superior	
		Inferior	Left Orbit, Inferior	
		Eyeball	Left Orbit, Eyeball	
		Medial	Left Orbit, Medial	
		Lateral	Left Orbit, Lateral	
	Right	Superior	Right Orbit, Superior	
		Inferior	Right Orbit, Inferior	
		Eyeball	Right Orbit, Eyeball	
		Medial	Right Orbit, Medial	
		Lateral	Right Orbit, Lateral	
Cheek	Left	Superior	Left Cheek, Superior	
		Inferior	Left Cheek, Inferior	
		Anterior	Left Cheek, Anterior	
		Posterior	Left Cheek, Posterior	
		Central	Left Cheek	
	Right	Superior	Right Cheek, Superior	
		Inferior	Right Cheek, Inferior	
		Anterior	Right Cheek, Anterior	
		Posterior	Right Cheek, Posterior	
		Central	Right Cheek	
Ear	Left	Superior	Left Ear, Superior	
		Inferior	Left Ear, Inferior	
		Anterior	Left Ear, Anterior	
		Posterior	Left Ear, Posterior	
	Right	Superior	Right Ear, Superior	
		Inferior	Right Ear, Inferior	
		Anterior	Right Ear, Anterior	
		Posterior	Right Ear, Posterior	
Nose		Superior	Nose, Superior	
		Inferior	Nose, Inferior	
		Anterior	Nose, Anterior	
		Left Lateral	Nose, Left Lateral	
		Right Lateral	Nose, Right Lateral	



Gross Division	Handedness	Region	Display Text	Code
Lip		Upper	Lip, Upper	
		Lower	Lip, Lower	
		Left Angle	Lip, Left Angle	
		Right Angle	Lip, Right Angle	
Jaw		Anterior	Jaw, Anterior	
		Inferior	Jaw, Inferior	
		Left Lateral	Jaw, Left Lateral	
		Right Lateral	Jaw, Right Lateral	
Neck		Anterior	Neck, Anterior	
		Left Lateral	Neck, Left Lateral	
		Right Lateral	Neck, Right Lateral	
		Posterior	Neck, Posterior	

## Torso

Gross Division	Handedness	Region	Display Text	Code
Thorax	Left	Clavicular region	Left Clavicular region	
		Axilla	Left Axilla	
		Lateral region	Left Lateral region, Thorax	
	Right	Clavicular region	Right Clavicular region	
		Axilla	Right Axilla	
		Lateral region	Right Lateral region, Thorax	
Sternum		Superior	Sternum, Superior	
		Inferior	Sternum, Inferior	

Gross Division	Handedness	Region	Display Text	Code
Breast	Left	Superior	Left Breast, Superior	
		Inferior	Left Breast, Inferior	
		Anterior	Left Breast, Anterior	
		Medial	Left Breast, Medial	
		Lateral	Left Breast, Lateral	
		Nipple	Left Breast, Nipple	
	Right	Superior	Right Breast, Superior	
		Inferior	Right Breast, Inferior	
		Anterior	Right Breast, Anterior	
		Medial	Right Breast, Medial	
		Lateral	Right Breast, Lateral	
		Nipple	Right Breast, Nipple	
Abdomen		Right upper quadrant	Abdomen, Right upper quadrant	
		Right lower quadrant	Abdomen, Right lower quadrant	
		Left upper quadrant	Abdomen, Left upper quadrant	
		Left lower quadrant	Abdomen, Left lower quadrant	
		Midline - upper	Abdomen, Midline - upper	
		Umbilical	Abdomen, Umbilical	
		Midline - lower	Abdomen, Midline - lower	
		Left flank	Abdomen, Left flank	
		Right flank	Abdomen, Right flank	
Back	Left	Scapular region	Left Back, Scapular region	
		Thoracic region	Left Back, Thoracic region	
		Lumbar region	Left Back, Lumbar region	
	Right	Scapular region	Right Back, Scapular region	
		Thoracic region	Right Back, Thoracic region	
		Lumbar region	Right Back, Lumbar region	
Spine		Thoracic	Spine, Thoracic	
		Lumbar	Spine, Lumbar	

## Pelvis

Gross Division	Handedness	Region	Display Text	Code
Spine/Gluteal cleft		Sacrum	Sacrum	
		Coccyx	Coccyx	
		Peri-anal	Peri-anal	
Buttock	Left	Superior	Left Buttock, Superior	
		Inferior	Left Buttock, Inferior	
		Central	Left Buttock	
		Medial	Left Buttock, Medial	
		Lateral	Left Buttock, Lateral	
	Right	Superior	Right Buttock, Superior	
		Inferior	Right Buttock, Inferior	
		Central	Right Buttock	
		Medial	Right Buttock, Medial	
		Lateral	Right Buttock, Lateral	
Misc. bony prominences	Left	Iliac Crest	Left Iliac Crest	
		Greater trochanter	Left Trochanter	
		Ischial Tuberosity	Left Ischial Tuberosity	
	Right	Iliac Crest	Right Iliac Crest	
		Greater trochanter	Right Trochanter	
		Ischial Tuberosity	Right Ischial Tuberosity	
Groin	Left		Left Groin	
	Right		Right Groin	
Genital Male		Scrotum	Scrotum	
		Penis	Penis	
		Perineum	Perineum	
Genital Female		Vulva	Vulva	
		Labia	Labia	
		Perineum	Perineum	

## Upper Extremity

Gross Division	Handedness	Region	Display Text	Code
Shoulder	Left	Superior	Left Shoulder, Superior	
		Anterior	Left Shoulder, Anterior	
		Posterior	Left Shoulder, Posterior	
		Lateral	Left Shoulder, Lateral	
	Right	Superior	Right Shoulder, Superior	
		Anterior	Right Shoulder, Anterior	
		Posterior	Right Shoulder, Posterior	
		Lateral	Right Shoulder, Lateral	
Upper Arm	Left	Anterior	Left Upper Arm, Anterior	
		Posterior	Left Upper Arm, Posterior	
		Medial	Left Upper Arm, Medial	
		Lateral	Left Upper Arm, Lateral	
		Circumferential	Left Upper Arm, Circumferential	
	Right	Anterior	Right Upper Arm, Anterior	
		Posterior	Right Upper Arm, Posterior	
		Medial	Right Upper Arm, Medial	
		Lateral	Right Upper Arm, Lateral	
		Circumferential	Right Upper Arm, Circumferential	
Elbow	Left	Anterior	Left Elbow, Anterior	
		Posterior	Left Elbow, Posterior	
		Medial	Left Elbow, Medial	
		Lateral	Left Elbow, Lateral	
		Circumferential	Left Elbow, Circumferential	
	Right	Anterior	Right Elbow, Anterior	
		Posterior	Right Elbow, Posterior	
		Medial	Right Elbow, Medial	
		Lateral	Right Elbow, Lateral	
		Circumferential	Right Elbow, Circumferential	

Gross Division	Handedness	Region	Display Text	Code
Forearm	Left	Anterior	Left Forearm, Anterior	
		Posterior	Left Forearm, Posterior	
		Medial	Left Forearm, Medial	
		Lateral	Left Forearm, Lateral	
		Circumferential	Left Forearm, Circumferential	
	Right	Anterior	Right Forearm, Anterior	
		Posterior	Right Forearm, Posterior	
		Medial	Right Forearm, Medial	
		Lateral	Right Forearm, Lateral	
		Circumferential	Right Forearm, Circumferential	
Wrist	Left	Anterior	Left Wrist, Anterior	
		Posterior	Left Wrist, Posterior	
		Medial	Left Wrist, Medial	
		Lateral	Left Wrist, Lateral	
		Circumferential	Left Wrist, Circumferential	
	Right	Anterior	Right Wrist, Anterior	
		Posterior	Right Wrist, Posterior	
		Medial	Right Wrist, Medial	
		Lateral	Right Wrist, Lateral	
		Circumferential	Right Wrist, Circumferential	
Hand	Left	Palm	Left Hand, Palm	
		Dorsum	Left Hand, Dorsum	
		Medial	Left Hand, Medial	
		Lateral	Left Hand, Lateral	
		Circumferential	Left Hand, Circumferential	
	Right	Palm	Right Hand, Palm	
		Dorsum	Right Hand, Dorsum	
		Medial	Right Hand, Medial	
		Lateral	Right Hand, Lateral	
		Circumferential	Right Hand, Circumferential	

Gross Division	Handedness	Region	Display Text	Code
Finger	Left	Thumb	Left Thumb	
		Index Finger	Left Index Finger	
		Middle Finger	Left Middle Finger	
		Ring Finger	Left Ring Finger	
		Little Finger	Left Little Finger	
	Right	Thumb	Right Thumb	
		Index Finger	Right Index Finger	
		Middle Finger	Right Middle Finger	
		Ring Finger	Right Ring Finger	
		Little Finger	Right Little Finger	

## Lower Extremity

Gross Division	Handedness	Region	Display Text	Code
Thigh	Left	Anterior	Left Thigh, Anterior	
		Posterior	Left Thigh, Posterior	
		Medial	Left Thigh, Medial	
		Lateral	Left Thigh, Lateral	
		Circumferential	Left Thigh, Circumferential	
	Right	Anterior	Right Thigh, Anterior	
		Posterior	Right Thigh, Posterior	
		Medial	Right Thigh, Medial	
		Lateral	Right Thigh, Lateral	
		Circumferential	Right Thigh, Circumferential	
Knee	Left	Anterior	Left Knee, Anterior	
		Posterior	Left Knee, Posterior	
		Medial	Left Knee, Medial	
		Lateral	Left Knee, Lateral	
		Circumferential	Left Knee, Circumferential	
	Right	Anterior	Right Knee, Anterior	
		Posterior	Right Knee, Posterior	
		Medial	Right Knee, Medial	
		Lateral	Right Knee, Lateral	
		Circumferential	Right Knee, Circumferential	

Gross Division	Handedness	Region	Display Text	Code
Lower leg	Left	Shin	Left Shin	
		Calf	Left Calf	
		Medial	Lower left leg, Medial	
		Lateral	Lower left leg, Lateral	
		Circumferential	Lower left leg, Circumferential	
	Right	Shin	Right Shin	
		Calf	Right Calf	
		Medial	Lower right leg, Medial	
		Lateral	Lower right leg, Lateral	
		Circumferential	Lower right leg, Circumferential	
Ankle	Left	Medial Malleolus	Left Medial Malleolus	
		Lateral Malleolus	Left Lateral Malleolus	
		Ankle Flexure	Left Ankle Flexure	
		Posterior	Left Ankle, Posterior	
	Right	Medial Malleolus	Right Medial Malleolus	
		Lateral Malleolus	Right Lateral Malleolus	
		Ankle Flexure	Right Ankle Flexure	
		Posterior	Right Ankle, Posterior	
Foot	Left	Dorsum	Left Foot, Dorsum	
		Sole	Left Foot, Sole	
		Medial	Left Foot, Medial	
		Lateral	Left Foot, Lateral	
		Heel	Left Foot, Heel	
	Right	Dorsum	Right Foot, Dorsum	
		Sole	Right Foot, Sole	
		Medial	Right Foot, Medial	
		Lateral	Right Foot, Lateral	
		Heel	Right Foot, Heel	

Gross Division	Handedness	Region	Display Text	Code
Toe	Left	Big	Left Toe, Big	
		Second	Left Toe, Second	
		Third	Left Toe, Third	
		Fourth	Left Toe, Fourth	
		Fifth	Left Toe, Fifth	
	Right	Big	Right Toe, Big	
		Second	Right Toe, Second	
		Third	Right Toe, Third	
		Fourth	Right Toe, Fourth	
		Fifth	Right Toe, Fifth	



## Appendix C: Wound State Definitions

Silhouette can record the current wound status or wound state with some optional notes. The table below shows the default set of states. In Silhouette version 4.11 these can only be modified by direct database manipulation.

### Selectable Wound States

The default wound state selected when creating a new wound is the state with the lowest order index.

Name	Order Index	Wounds Display As
Open	0	Active
Healed	1	Inactive
Released from Follow-up	2	Inactive
Amputated	3	Inactive

### Wound State Notes

The user is given the opportunity to record some relevant notes based on the wound state selected.

#### Wound State Notes: Open

Item	Properties
Recurring	Data type    Boolean Active        Yes Required     No Variable     'recurring ' <i>Note: The variable name has a space trailing character.</i> Export name   Wound State - Recurring

#### Wound State Notes: Healed

There are no default notes captured with the Healed state.

## Wound State Notes: Released from Follow-up

Item	Properties
Wound release reason	Data type      List (single selection) Active          Yes Required        No Variable        wound_release_reason Export name    Wound State - Wound release reason Selectable list items: <ul style="list-style-type: none"> <li>• Discharged with wound</li> <li>• Patient lost to follow-up</li> <li>• Specialist wound care not required</li> <li>• Other</li> </ul>
Wound release comment	Data type      Text Active          Yes Required        No Variable        wound_release_comment Multi-line      No Max Length    255 Export name    Wound State - Wound release comment

## Wound State Notes: Amputated

Item	Properties
Amputation category	Data type      List (single selection) Active          Yes Required        No Variable        amputation_category Export name    Wound State - Amputation category Selectable list items: <ul style="list-style-type: none"> <li>• Major</li> <li>• Minor</li> </ul>

## Appendix D: Notes Definitions

In addition to images and measurements SilhouetteConnect and SilhouetteCentral can be used to capture notes. Notes can be associated with a particular patient, visit or wound assessment. The following section of this document outlines the note fields available for clinicians to enter.

The notes described in this appendix reflect the default set of notes that SilhouetteCentral and SilhouetteConnect are setup with. They do not show any customizations made.

### Patient admission

#### Details

Item	Variable	Data Type	Properties
Expected Discharge	expected_discharge_date	Date	Active Yes Required No Visible Yes Persistent No
Palliative Care	palliative_care	Boolean	Active Yes Required No Visible Yes Persistent No

### Physicians

Item	Variable	Data Type	Properties
Treating	admission_and_discharge_treating_physician	Text <ul style="list-style-type: none"> <li>Max Length: 255</li> <li>Multi-Line: No</li> </ul>	Active Yes Required No Visible Yes Persistent No
Referring	admission_and_discharge_referring_physician	Text <ul style="list-style-type: none"> <li>Max Length: 255</li> <li>Multi-Line: No</li> </ul>	Active Yes Required No Visible Yes Persistent No

## Patient Details

### Details

Item	Variable	Data Type	Properties
Patient ID	details_patient_id	Text <ul style="list-style-type: none"> <li>• Max Length: 128</li> <li>• Multi-Line: No</li> </ul>	Active Yes Required Yes Visible Yes Persistent No
Unit	details_unit	Unit	Active Yes Required Yes Visible Yes Persistent No
Last Name	details_last_name	Text <ul style="list-style-type: none"> <li>• Max Length: 128</li> <li>• Multi-Line: No</li> </ul>	Active Yes Required Yes Visible Yes Persistent No
First Name	details_first_name	Text <ul style="list-style-type: none"> <li>• Max Length: 128</li> <li>• Multi-Line: No</li> </ul>	Active Yes Required Yes Visible Yes Persistent No
Middle Name	details_middle_name	Text <ul style="list-style-type: none"> <li>• Max Length: 128</li> <li>• Multi-Line: No</li> </ul>	Active Yes Required No Visible Yes Persistent No
Date of Birth	details_date_of_birth	Date	Active Yes Required Yes Visible Yes Persistent No

Item	Variable	Data Type	Properties
Gender	details_is_female	List (single selection)	Active Yes Required Yes Visible Yes Persistent No
	<ul style="list-style-type: none"> <li>• Male</li> <li>• Female</li> </ul>		

## Address

Item	Variable	Data Type	Properties
Street	address_street	Text <ul style="list-style-type: none"> <li>• Max Length: 255</li> <li>• Multi-Line: No</li> </ul>	Active Yes Required No Visible Yes Persistent No
Suburb	address_suburb	Text <ul style="list-style-type: none"> <li>• Max Length: 255</li> <li>• Multi-Line: No</li> </ul>	Active Yes Required No Visible Yes Persistent No
City	address_city	Text <ul style="list-style-type: none"> <li>• Max Length: 255</li> <li>• Multi-Line: No</li> </ul>	Active Yes Required No Visible Yes Persistent No
State	address_state	Text <ul style="list-style-type: none"> <li>• Max Length: 255</li> <li>• Multi-Line: No</li> </ul>	Active Yes Required No Visible Yes Persistent No
Postcode	address_postcode	Text <ul style="list-style-type: none"> <li>• Max Length: 50</li> <li>• Multi-Line: No</li> </ul>	Active Yes Required No Visible Yes Persistent No

Item	Variable	Data Type	Properties
Country	address_country	Text <ul style="list-style-type: none"> <li>• Max Length: 255</li> <li>• Multi-Line: No</li> </ul>	Active Yes Required No Visible Yes Persistent No

## Contact

Item	Variable	Data Type	Properties
Home Phone	contact_home_phone	Text <ul style="list-style-type: none"> <li>• Max Length: 50</li> <li>• Multi-Line: No</li> </ul>	Active Yes Required No Visible Yes Persistent No
Mobile Phone	contact_mobile_phone	Text <ul style="list-style-type: none"> <li>• Max Length: 50</li> <li>• Multi-Line: No</li> </ul>	Active Yes Required No Visible Yes Persistent No
Work Phone	contact_work_phone	Text <ul style="list-style-type: none"> <li>• Max Length: 50</li> <li>• Multi-Line: No</li> </ul>	Active Yes Required No Visible Yes Persistent No

## Patient discharge

### Details

Item	Variable	Data Type	Properties
Reason	admission_status	List (single selection)	Active Yes Required No Visible Yes Persistent No
	<ul style="list-style-type: none"> <li>• Discharged</li> <li>• Lost to follow-up</li> <li>• Deceased</li> </ul>		

Item	Variable	Data Type	Properties
Comments	discharge_comments	Text <ul style="list-style-type: none"> <li>• Max Length: 255</li> <li>• Multi-Line: Yes</li> </ul>	Active Yes Required No Visible Yes Persistent No

## Assessment of lower limb function

### Right

Item	Variable	Data Type	Properties
Warmth	lower_limb_assessment_warmth_right_leg	List (single selection)	Active Yes Required No Visible Yes Persistent No
	<ul style="list-style-type: none"> <li>• Cold</li> <li>• Cool</li> <li>• Warm</li> <li>• Hot</li> </ul>		
Venous signs	lower_limb_assessment_venous_signs_right_leg	List (multiple selection)	Active Yes Required No Visible Yes Persistent No
	<ul style="list-style-type: none"> <li>• Varicose veins</li> <li>• Atrophie blanche</li> <li>• Eczema</li> <li>• Lipodermatosclerosis</li> <li>• Hemosiderin staining</li> </ul>		
Calf muscle effectiveness	lower_limb_assessment_calf_muscle_effectiveness_right	Boolean	Active Yes Required No Visible Yes Persistent No

Item	Variable	Data Type	Properties		
Arterial signs	lower_limb_assessment_arterial_signs_right_leg	List (multiple selection)	Active	Yes	
			Required	No	
				Visible	Yes
				Persistent	No
		<ul style="list-style-type: none"> <li>• Hairless</li> <li>• Shiny</li> <li>• Capillary refill &gt; 3 seconds</li> <li>• Dependent rubor</li> <li>• Atrophic nails</li> <li>• Cyanosis</li> </ul>			
Pulses palpable	lower_limb_assessment_pulses_palpable_right	List (multiple selection)	Active	Yes	
			Required	No	
				Visible	Yes
				Persistent	No
		<ul style="list-style-type: none"> <li>• Dorsalis pedis</li> <li>• Posterior tibial</li> </ul>			
Dorsalis pedis pressure	lower_limb_assessment_dorsalis_pedis_pressure_right	Decimal	Active	Yes	
				Required	No
				Visible	Yes
				Persistent	No
Posterior tibial pressure	lower_limb_assessment_posterior_tibial_pressure_right	Decimal	Active	Yes	
				Required	No
				Visible	Yes
				Persistent	No
Brachial pressure	lower_limb_assessment_brachial_pressure_right	Decimal	Active	Yes	
				Required	No
				Visible	Yes
				Persistent	No



Item	Variable	Data Type	Properties
Pulse signal	lower_limb_assessment_pulse_signal_right	List (multiple selection)	Active Yes Required No Visible Yes Persistent No
	<ul style="list-style-type: none"> <li>• Monophasic</li> <li>• Biphasic</li> <li>• Triphasic</li> </ul>		
ABPI result	lower_limb_assessment_abpi_result_right	Decimal	Active Yes Required No Visible Yes Persistent No
Toe pressure	lower_limb_assessment_toe_pressure_right	Decimal	Active Yes Required No Visible Yes Persistent No
TBPI	lower_limb_assessment_tbpi_right	Decimal	Active Yes Required No Visible Yes Persistent No
Thinnest ankle	lower_limb_assessment_thinnest_ankle_right	Decimal (cm)	Active Yes Required No Visible Yes Persistent No
Widest calf	lower_limb_assessment_widest_calf_right	Decimal (cm)	Active Yes Required No Visible Yes Persistent No

## Ambulation

Item	Variable	Data Type	Properties
Ambulation	lower_limb_assessment_ambulation	List (single selection)	Active Yes Required No Visible Yes Persistent No
	<ul style="list-style-type: none"> <li>• Independent - no aid or assistance</li> <li>• Independent with mobility aid or assistance</li> <li>• Chair bound</li> <li>• Bed bound</li> </ul>		
Client report of walking duration (minutes)	lower_limb_assessment_client_report_of_walking_duration_minutes	Decimal	Active Yes Required No Visible Yes Persistent No

## Left

Item	Variable	Data Type	Properties
Warmth	lower_limb_assessment_warmth_left_leg	List (single selection)	Active Yes Required No Visible Yes Persistent No
	<ul style="list-style-type: none"> <li>• Cold</li> <li>• Cool</li> <li>• Warm</li> <li>• Hot</li> </ul>		

Item	Variable	Data Type	Properties
Venous signs	lower_limb_assessment_venous_signs_left_leg	List (multiple selection)	Active Yes Required No Visible Yes Persistent No
	<ul style="list-style-type: none"> <li>• Varicose veins</li> <li>• Atrophie blanche</li> <li>• Eczema</li> <li>• Lipodermatosclerosis</li> <li>• Hemosiderin staining</li> </ul>		
Calf muscle effectiveness	lower_limb_assessment_calf_muscle_effectiveness_left	Boolean	Active Yes Required No Visible Yes Persistent No
Arterial signs	lower_limb_assessment_arterial_signs_left_leg	List (multiple selection)	Active Yes Required No Visible Yes Persistent No
	<ul style="list-style-type: none"> <li>• Hairless</li> <li>• Shiny</li> <li>• Capillary refill &gt; 3 seconds</li> <li>• Dependent rubor</li> <li>• Atrophic nails</li> <li>• Cyanosis</li> </ul>		
Pulses palpable	lower_limb_assessment_pulses_palpable_left	List (multiple selection)	Active Yes Required No Visible Yes Persistent No
	<ul style="list-style-type: none"> <li>• Dorsalis pedis</li> <li>• Posterior tibial</li> </ul>		

Item	Variable	Data Type	Properties	
Dorsalis pedis pressure	lower_limb_assessment_ dorsalis_pedis_pressure_left	Decimal	Active	Yes
			Required	No
			Visible	Yes
			Persistent	No
Posterior tibial pressure	lower_limb_assessment_ posterior_tibial_pressure_left	Decimal	Active	Yes
			Required	No
			Visible	Yes
			Persistent	No
Brachial pressure	lower_limb_assessment_ brachial_pressure_left	Decimal	Active	Yes
			Required	No
			Visible	Yes
			Persistent	No
Pulse signal	lower_limb_assessment_ pulse_signal_left	List (multiple selection)	Active	Yes
			Required	No
			Visible	Yes
			Persistent	No
	<ul style="list-style-type: none"> <li>• Monophasic</li> <li>• Biphasic</li> <li>• Triphasic</li> </ul>			
ABPI result	lower_limb_assessment_abpi_ result_left	Decimal	Active	Yes
			Required	No
			Visible	Yes
			Persistent	No
Toe pressure	lower_limb_assessment_toe_ pressure_left	Decimal	Active	Yes
			Required	No
			Visible	Yes
			Persistent	No
TBPI	lower_limb_assessment_tbpi_ left	Decimal	Active	Yes
			Required	No
			Visible	Yes
			Persistent	No

Item	Variable	Data Type	Properties
Thinnest ankle	lower_limb_assessment_thinnest_ankle_left	Decimal (cm)	Active Yes Required No Visible Yes Persistent No
Widest calf	lower_limb_assessment_widest_calf_left	Decimal (cm)	Active Yes Required No Visible Yes Persistent No

## Comments

Item	Variable	Data Type	Properties
Comments	lower_limb_assessment_comments	Text <ul style="list-style-type: none"> <li>Max Length: 255</li> <li>Multi-Line: Yes</li> </ul>	Active Yes Required No Visible Yes Persistent No

## Visit Assessment

### Vital signs

Item	Variable	Data Type	Properties
Weight	vital_signs_weight	Decimal (kg)	Active Yes Required No Visible Yes Persistent No
Height	vital_signs_height	Decimal (cm)	Active Yes Required No Visible Yes Persistent No
Pulse rate	vital_signs_pulse_rate	Decimal (/min)	Active Yes Required No Visible Yes Persistent No

Item	Variable	Data Type	Properties	
Respiration rate	vital_signs_respiration_rate	Decimal (/min)	Active	Yes
			Required	No
			Visible	Yes
			Persistent	No
Blood pressure, systolic	vital_signs_blood_pressure_systolic	Decimal (mmHg)	Active	Yes
			Required	No
			Visible	Yes
			Persistent	No
Blood pressure, diastolic	vital_signs_blood_pressure_diastolic	Decimal (mmHg)	Active	Yes
			Required	No
			Visible	Yes
			Persistent	No
Temperature	vital_signs_temperature	Decimal (°C)	Active	Yes
			Required	No
			Visible	Yes
			Persistent	No
Blood glucose level	vital_signs_blood_glucose_level	Decimal (mmol/L)	Active	Yes
			Required	No
			Visible	Yes
			Persistent	No

### Related Pain (Non-Wound)

Item	Variable	Data Type	Properties	
Location	related_pain_nonwound_location	Text	Active	Yes
		<ul style="list-style-type: none"> <li>• Max Length: 255</li> <li>• Multi-Line: No</li> </ul>	Required	No
			Visible	Yes
			Persistent	No
Scale (0-10)	related_pain_nonwound_scale_010	Integer	Active	Yes
		<ul style="list-style-type: none"> <li>• Interval: 1</li> <li>• Range: 0 to 10</li> </ul>	Required	No
			Visible	Yes
			Persistent	No

Item	Variable	Data Type	Properties
Occurrence	related_pain_nonwound_occurrence	List (multiple selection)	Active Yes Required No Visible Yes Persistent No
	<ul style="list-style-type: none"> <li>• At dressing change</li> <li>• Night pain</li> <li>• On walking</li> <li>• On elevation</li> <li>• Dependent</li> <li>• Other</li> </ul>		
Comments	related_pain_nonwound_comments	Text <ul style="list-style-type: none"> <li>• Max Length: 255</li> <li>• Multi-Line: Yes</li> </ul>	Active Yes Required No Visible Yes Persistent No

## Edema

Item	Variable	Data Type	Properties
Pitting	edema_pitting	Boolean	Active Yes Required No Visible Yes Persistent No
Location (right)	edema_location_right	List (multiple selection)	Active Yes Required No Visible Yes Persistent No
	<ul style="list-style-type: none"> <li>• Toes</li> <li>• Foot</li> <li>• Gaiter</li> <li>• Above gaiter</li> <li>• Knee</li> <li>• Thigh</li> </ul>		

Item	Variable	Data Type	Properties
Location (left)	edema_location_left	List (multiple selection)	Active Yes Required No Visible Yes Persistent No
	<ul style="list-style-type: none"> <li>• Toes</li> <li>• Foot</li> <li>• Gaiter</li> <li>• Above gaiter</li> <li>• Knee</li> <li>• Thigh</li> </ul>		
Location: Other	edema_location_other	Text <ul style="list-style-type: none"> <li>• Max Length: 255</li> <li>• Multi-Line: No</li> </ul>	Active Yes Required No Visible Yes Persistent No
Comments	edema_comments	Text <ul style="list-style-type: none"> <li>• Max Length: 255</li> <li>• Multi-Line: Yes</li> </ul>	Active Yes Required No Visible Yes Persistent No

### Factors Affecting Healing

Item	Variable	Data Type	Properties
Impaired sensation (left)	factors_affecting_healing_impaired_sensation_left	Boolean	Active Yes Required No Visible Yes Persistent No
Impaired sensation (right)	factors_affecting_healing_impaired_sensation_right	Boolean	Active Yes Required No Visible Yes Persistent No



Item	Variable	Data Type	Properties
Braden outcome	factors_affecting_healing_ braden_outcome	List (single selection)	Active    Yes Required    No Visible    Yes Persistent    No
	<ul style="list-style-type: none"> <li>• Low risk</li> <li>• Mod risk</li> <li>• High risk</li> <li>• Very high risk</li> </ul>		
PURA outcome	factors_affecting_healing_ pura_outcome	List (single selection)	Active    Yes Required    No Visible    Yes Persistent    No
	<ul style="list-style-type: none"> <li>• Low risk</li> <li>• Mod risk</li> <li>• High risk</li> <li>• Very high risk</li> </ul>		
Nutritional Risk screen	factors_affecting_healing_ nutritional_risk_screen	List (multiple selection)	Active    Yes Required    No Visible    Yes Persistent    No
	<ul style="list-style-type: none"> <li>• Obvious underweight-frailty</li> <li>• Unintentional weight loss</li> <li>• Reduced appetite or food and fluid intake</li> <li>• Mouth teeth problems</li> <li>• Swallowing problems</li> <li>• Follows a special diet</li> <li>• Needs assistance to shop for food</li> <li>• Needs assistance to prepare food</li> <li>• Needs assistance to feed self</li> <li>• Obvious overweight affecting life quality</li> <li>• Unintentional weight gain</li> </ul>		

Item	Variable	Data Type	Properties
BMI outcome	factors_affecting_healing_ bmi_outcome	List (single selection)	Active      Yes Required    No Visible      Yes Persistent   No
	<ul style="list-style-type: none"> <li>• Underweight (&lt;18.5)</li> <li>• Normal (18.5 - 24.9)</li> <li>• Overweight (25 - 29.9)</li> <li>• Obese (&gt;30)</li> </ul>		

## Wound Assessment

### Images

Item	Variable	Data Type	Properties
Wound Images	images_wound_images	Image Capture	Active      Yes Required    No Visible      Yes
	Trace images screen is enabled.		

## Details

Item	Variable	Data Type	Properties
Etiology	wound_history_etiology	List (single selection)	Active Yes Required No Visible Yes Persistent Yes
	<ul style="list-style-type: none"> <li>• Pressure Ulcer: Stage 1</li> <li>• Pressure Ulcer: Stage 2</li> <li>• Pressure Ulcer: Stage 3</li> <li>• Pressure Ulcer: Stage 4</li> <li>• Pressure Ulcer: Unstageable (dressing/device)</li> <li>• Pressure Ulcer: Unstageable (eschar/slough)</li> <li>• Deep Tissue Injury</li> <li>• Venous Ulcer</li> <li>• Arterial insufficiency</li> <li>• Mixed Venous/Arterial</li> <li>• Diabetic</li> <li>• Neuropathic: Non-diabetic</li> <li>• Surgical: Closed</li> <li>• Surgical: Full thickness</li> <li>• Surgical: Partial thickness</li> <li>• Surgical: Dehiscence</li> <li>• Drainage Device</li> <li>• Trauma: Full thickness</li> <li>• Trauma: Partial thickness</li> <li>• Trauma: Superficial</li> <li>• Skin tear: Category 1</li> <li>• Skin tear: Category 2a</li> <li>• Skin tear: Category 2b</li> <li>• Skin tear: Category 3</li> <li>• Burn: Superficial thickness</li> <li>• Burn: Partial thickness</li> <li>• Burn: Full thickness</li> <li>• Cancerous: Fungating lesion</li> <li>• Cancerous: Ulcerating lesion</li> <li>• Cancerous: Other</li> <li>• Skin graft</li> <li>• Donor site</li> <li>• Pilonidal wound</li> </ul>		

Item	Variable	Data Type	Properties
Wound Margins	wound_margins_sloping	List (multiple selection)	Active Yes Required No Visible Yes Persistent No
	<ul style="list-style-type: none"> <li>• Sloping</li> <li>• Punched out</li> <li>• Rolled</li> <li>• Everted</li> <li>• Undermining</li> <li>• Sinus</li> <li>• Inflamed</li> </ul>		
Surrounding Skin	surrounding_skin_tissue_paper_skin	List (multiple selection)	Active Yes Required No Visible Yes Persistent No
	<ul style="list-style-type: none"> <li>• 'Tissue paper' skin</li> <li>• Peri-wound edema</li> <li>• Macerated</li> <li>• Erythema</li> <li>• Inflammation</li> <li>• Pustules</li> <li>• Eczema</li> <li>• Dry/scaly</li> <li>• Healthy</li> </ul>		
Signs of Critical Colonization or Infection	signs_of_critical_colonization_or_infection_cellulitis	List (multiple selection)	Active Yes Required No Visible Yes Persistent No
	<ul style="list-style-type: none"> <li>• Cellulitis</li> <li>• Suppuration</li> <li>• Lymphangitis</li> <li>• Sepsis</li> <li>• Bacteremia</li> <li>• Granulation changes</li> <li>• Exudate increase</li> <li>• Increase/new pain</li> <li>• Impaired/delayed healing</li> <li>• Wound breakdown/new slough</li> </ul>		

Item	Variable	Data Type	Properties
Exudate Volume	exudate_volume	List (single selection)	Active Yes Required No Visible Yes Persistent No
	<ul style="list-style-type: none"> <li>• None</li> <li>• Low</li> <li>• Moderate</li> <li>• High</li> </ul>		
Exudate Type	exudate_type	List (single selection)	Active Yes Required No Visible Yes Persistent No
	<ul style="list-style-type: none"> <li>• Serous</li> <li>• Serosanguineous</li> <li>• Sanguineous</li> <li>• Purulent</li> </ul>		

**Wound Pain**

Item	Variable	Data Type	Properties
Frequency	wound_pain_frequency	List (single selection)	Active Yes Required No Visible Yes Persistent No
	<ul style="list-style-type: none"> <li>• Absent</li> <li>• Intermittent</li> <li>• Continuous</li> </ul>		

Item	Variable	Data Type	Properties
Nature of pain	wound_pain_nature_of_pain	List (multiple selection)	Active Yes Required No Visible Yes Persistent No
	<ul style="list-style-type: none"> <li>• Throbbing</li> <li>• Shooting</li> <li>• Stabbing</li> <li>• Sharp</li> <li>• Cramping</li> <li>• Gnawing</li> <li>• Hot/burning</li> <li>• Aching</li> <li>• Heavy</li> <li>• Tender</li> <li>• Splitting</li> <li>• Tiring/exhausting</li> <li>• Sickening</li> <li>• Fearful</li> <li>• Cruel/punishing</li> <li>• Other</li> </ul>		
Current interventions	wound_pain_current_interventions	List (multiple selection)	Active Yes Required No Visible Yes Persistent No
	<ul style="list-style-type: none"> <li>• Pharmacological</li> <li>• Non-pharmacological</li> <li>• Dressing/removal technique</li> <li>• Other</li> </ul>		
At dressing change (0-10)	wound_pain_at_dressing_change_010	Integer <ul style="list-style-type: none"> <li>• Interval: 1</li> <li>• Range: 0 to 10</li> </ul>	Active Yes Required No Visible Yes Persistent No
Night pain (0-10)	wound_pain_night_pain_010	Integer <ul style="list-style-type: none"> <li>• Interval: 1</li> <li>• Range: 0 to 10</li> </ul>	Active Yes Required No Visible Yes Persistent No

Item	Variable	Data Type	Properties
On walking (0-10)	wound_pain_on_walking_010	Integer <ul style="list-style-type: none"> <li>Interval: 1</li> <li>Range: 0 to 10</li> </ul>	Active Yes Required No Visible Yes Persistent No
On elevation (0-10)	wound_pain_on_elevation_010	Integer <ul style="list-style-type: none"> <li>Interval: 1</li> <li>Range: 0 to 10</li> </ul>	Active Yes Required No Visible Yes Persistent No
Dependent (0-10)	wound_pain_dependent_010	Integer <ul style="list-style-type: none"> <li>Interval: 1</li> <li>Range: 0 to 10</li> </ul>	Active Yes Required No Visible Yes Persistent No
Other (0-10)	wound_pain_other_010	Integer <ul style="list-style-type: none"> <li>Interval: 1</li> <li>Range: 0 to 10</li> </ul>	Active Yes Required No Visible Yes Persistent No
Comments	wound_pain_other_description	Text <ul style="list-style-type: none"> <li>Max Length: 255</li> <li>Multi-Line: Yes</li> </ul>	Active Yes Required No Visible Yes Persistent No

## Comments

Item	Variable	Data Type	Properties
Comments	assessment_comments	Text <ul style="list-style-type: none"> <li>Max Length: 255</li> <li>Multi-Line: Yes</li> </ul>	Active Yes Required No Visible Yes Persistent No

## Investigation History

### Investigation History

Item	Variable	Data Type	Properties
Diagnostic	investigation_history_diagnostic	List (multiple selection)	Active Yes Required No Visible Yes Persistent No
	<ul style="list-style-type: none"> <li>• Venous duplex</li> <li>• Arterial duplex</li> <li>• Angiogram</li> <li>• X-ray</li> </ul>		
Pathology	investigation_history_pathology	List (multiple selection)	Active Yes Required No Visible Yes Persistent No
	<ul style="list-style-type: none"> <li>• Wound biopsy</li> <li>• Hb</li> <li>• Thyroid function</li> <li>• Albumin</li> <li>• Creatinine</li> <li>• HbA1c</li> <li>• FBC</li> </ul>		
Comments	investigation_history_comments	Text <ul style="list-style-type: none"> <li>• Max Length: 255</li> <li>• Multi-Line: Yes</li> </ul>	Active Yes Required No Visible Yes Persistent No



## Medical History

### Medical History

Item	Variable	Data Type	Properties
Current conditions	medical_history_current_conditions	List (multiple selection)	Active Yes Required No Visible Yes Persistent No
	<ul style="list-style-type: none"> <li>• Diabetes</li> <li>• Cardiac condition</li> <li>• Anemia</li> <li>• COAD</li> <li>• Rheumatoid arthritis</li> <li>• Autoimmune disorder</li> <li>• Hepatic failure</li> <li>• Malignancy</li> <li>• Peripheral vascular disease</li> <li>• Neurological disorder</li> <li>• Inflammatory bowel disease</li> <li>• Renal disease</li> <li>• Other</li> </ul>		
Contributing factors	medical_history_contributing_factors	List (multiple selection)	Active Yes Required No Visible Yes Persistent No
	<ul style="list-style-type: none"> <li>• Reduced mobility</li> <li>• Pressure</li> <li>• Shearing</li> <li>• Friction</li> <li>• Impaired sensation</li> <li>• Edema</li> <li>• Nutritional factors</li> <li>• Obesity</li> <li>• Radiotherapy</li> <li>• Smoking</li> <li>• Venous hypertension</li> <li>• Ischemia</li> <li>• Other</li> </ul>		

Item	Variable	Data Type	Properties
Smoking History	smoking_history	List (single selection)	Active Yes Required No Visible Yes Persistent No
	<ul style="list-style-type: none"> <li>• Smoker</li> <li>• Past smoker</li> <li>• Never smoked</li> </ul>		
Current cigarette consumption	current_cigarette_consumption	List (single selection)	Active Yes Required No Visible Yes Persistent No
	<ul style="list-style-type: none"> <li>• 1-10 per day</li> <li>• 11-20 per day</li> <li>• 21 or more per day</li> </ul>		
Past medical history	medical_history_past_medical_history	Text <ul style="list-style-type: none"> <li>• Max Length: 255</li> <li>• Multi-Line: Yes</li> </ul>	Active Yes Required No Visible Yes Persistent No
Comments	medical_history_comments	Text <ul style="list-style-type: none"> <li>• Max Length: 255</li> <li>• Multi-Line: Yes</li> </ul>	Active Yes Required No Visible Yes Persistent No

## Medication

### Medication

Item	Variable	Data Type	Properties
Medicines	medication_medicines	List (multiple selection)	Active Yes Required No Visible Yes Persistent No
	<ul style="list-style-type: none"> <li>• NSAIDS</li> <li>• Cytotoxics</li> <li>• Anti-coagulants</li> <li>• Beta blockers</li> <li>• Immune suppressants</li> <li>• Steroids</li> <li>• Antibiotics</li> <li>• Other</li> </ul>		
Comments	medication_comments	Text <ul style="list-style-type: none"> <li>• Max Length: 255</li> <li>• Multi-Line: Yes</li> </ul>	Active Yes Required No Visible Yes Persistent No

### Sensitivities

Item	Variable	Data Type	Properties
Medicines	medication_sensitivities_medicines	Text <ul style="list-style-type: none"> <li>• Max Length: 255</li> <li>• Multi-Line: No</li> </ul>	Active Yes Required No Visible Yes Persistent No
Dressings and adhesives	medication_sensitivities_dressings_and_adhesives	Text <ul style="list-style-type: none"> <li>• Max Length: 255</li> <li>• Multi-Line: No</li> </ul>	Active Yes Required No Visible Yes Persistent No
Other	medication_sensitivities_other	Text <ul style="list-style-type: none"> <li>• Max Length: 255</li> <li>• Multi-Line: No</li> </ul>	Active Yes Required No Visible Yes Persistent No

## Appendix E: Order and Encounter Notes Definitions

Silhouette can record any piece of data from an incoming order message using configurable notes in either the encounter or the order.

The default set of Order and Encounter notes are included in this appendix for convenience, however, an up-to-date representation of the notes can be downloaded from SilhouetteCentral using the **Integration Definitions** on the **Silhouette Configuration** page in the Admin section of the application.

### Order Notes

The default order notes set is not configurable and notes cannot be disabled as they are used to provide order functionality within Silhouette. Additional order notes can be added by contacting ARANZ Medical Support.

The default order notes have variable names assigned so that they can be referenced in conditional expressions and they are listed in the table below.

Item	Properties	
Order Number	Data type	Text (Single Line)
	Variable	order_orderid
	Integration Identifier	Yes
Scheduled Date	Data type	Date
	Variable	order_scheduleddate
	Integration Identifier	No
Status	Data type	Single Select List
	Variable	order_status
	Integration Identifier	No
	List Lookup Items:	
	• Active	
	• Completed	
Description	Data type	Text (Multi Line)
	Variable	order_description
	Integration Identifier	No
Maximum Assessment Count	Data type	Integer
	Variable	order_maxassessments
	Integration Identifier	No

### Encounter Notes

The encounter notes are configurable by ARANZ Medical Support.

Item	Properties	
Facility	Data type	Single Select Lookup
	Variable	encounter_facility
	Integration Identifier	No
	Default list lookup items:	
	<ul style="list-style-type: none"> <li data-bbox="497 479 1412 524">• Facility A</li> <li data-bbox="497 533 1412 577">• Facility B</li> </ul>	
Account Number	Data type	Text (Single Line)
	Variable	encounter_encounter_id
	Integration Identifier	Yes

## Appendix F: Clinical Data Export Format

When exporting clinical data into Comma Separated Values (CSV) documents the export includes the following sets of columns. All values in the csv file output are surrounded by double quote marks (") to allow for text that contains commas (,), line breaks and other special characters.

The output files are UTF-8 encoded and use Windows style line ends.

The sets of columns are generally included in the order they are listed below.

### ISO 8601 Date and Time Format

Many of the observation dates listed in the export are in a ISO 8601 compatible format, which includes the time in 24hr time and the timezone offset. For example, the assessment date *2018-05-29T10:05:25+12* means the assessment was taken on the 29th May 2018 at 10:05 AM in a timezone that is offset +12 hours from universal coordinated time.

### Silhouette Identifiers

The data export does not include the Silhouette identifier columns in a default configuration. Silhouette identifiers are only included in the data export if the organizational setting **Include identifiers in CSV exports** is enabled by ARANZ Medical support for your SilhouetteCentral instance.

The Silhouette identifiers columns can be useful to retain an identifier that is not modified by data changes within Silhouette.

For example, if the patient's name is updated then a new export will have the updated patient name. Rows in the old and new exports can be confirmed as the same patient using the PatientId column.

Column Name	Example Data	Description
PatientId	b24ce1f3-2aef-4fab-8d35-1afc85a31a80	A unique identifier used to identify the patient within Silhouette.
AssessmentId	b24ce1f3-2aef-4fab-8d35-1afc85a31a80	A unique identifier used to identify the assessment within Silhouette.  This field is left empty for wound data exports where the row does not have an associated assessment.
WoundId	b24ce1f3-2aef-4fab-8d35-1afc85a31a80	A unique identifier used to identify the wound within Silhouette.  This field is left empty for data exports of patient level assessments.

Column Name	Example Data	Description
AnatomyId	b24ce1f3-2aef-4fab-8d35-1afc85a31a80	A unique identifier used to identify the anatomical site selected for the wound within Silhouette.  This field is left empty for data exports of patient level assessments.
UnitId	b24ce1f3-2aef-4fab-8d35-1afc85a31a80	A unique identifier used to identify the unit selected for the patient within Silhouette.

These columns are included in the data export as the first set of columns, if they are enabled. The exception is the UnitId column, which is included just before the Unit column, wherever the Unit column appears in the patient information.

## Observation Information

The observation information columns are a static set of columns with data about the assessment or observation being exported.

If the export is an assessment export the following columns are provided.

Column Name	Example Data	Description
Assessment Type	Wound Assessment	The name of the assessment type being exported.
Assessment Date	2018-05-29T10:05:25+12	The date and time of the assessment in an ISO 8601 format.
Assessment Time Zone	Auckland/Pacific	The time zone name from the IANA Time Zone Database associated to the Assessment Date column.

If the export is a wound export the following columns are provided.

Column Name	Example Data	Description
Observation Date	2018-05-29T10:05:25+12	The date and time recorded with the wound observation in an ISO 8601 format.

Column Name	Example Data	Description
Observation Timezone	Auckland/Pacific	The time zone name from the IANA Time Zone Database associated to the Assessment Date column.

## Wound Information

The wound information columns are a static set of columns with data about the wound. These columns are left empty if the export is exporting a patient level assessment.

Column Name	Example Data	Description
Wound Label	A	The label for the wound. The value is either a number or a letter, as defined in the Silhouette organizational settings.
Wound Anatomical Site	Left Foot, Heel	The anatomical site label for the wound as it appears in Silhouette.
Wound Auxiliary Text		The auxiliary text entered for the wound.
Wound Baseline Date	2019-07-01T10:35:00+12	The date and time recorded as the wound baseline in a ISO 8601 compatible format.  This may or may not be the same as the baseline measurement time. The baseline measurement for the wound is the first non-zero measurement recorded for the wound on or after this time stamp.
Wound Baseline Timezone	Pacific/Auckland	The time zone name from the IANA Time Zone Database associated to the Wound Baseline Date column.

## Patient Notes

The patient notes columns are a dynamic set of columns, which include all the patient notes defined within Silhouette. The column names can be set in the notes configuration.



The values listed in the patient notes fields are the current values recorded with Silhouette, not the value of the patient note recorded at the time of the assessment being exported.

For example. When a patients name is updated in Silhouette and then an assessment export is performed, the export will show the updated patient name for all historical assessments.

The following table describes the columns that can appear in the data export based on the data types of the patient note fields.

Data Type	Example Value(s)	Description
Boolean	Yes No	Shows 'Yes' or 'No' if there is a selection made by the user.  Shows an empty column value if no selection as been made for the corresponding note field.
Date	1950-11-30	Shows the date in the format YYYY-MM-DD.
Decimal	2.1	The value entered or selected by the user.
Integer	2	The value entered or selected by the user.
List	Item 1	The text of the look-up value selected by the user.  Look-up values that have been made inactive will still show in the export where they were selected for historical assessments.
Multi-Select List	Item 1;Item 3	The semi-colon (;) separated list of the text from the selected items in the multi-select list.  Look-up values that have been made inactive will still show in the export where they were selected in historical assessments.

Data Type	Example Value(s)	Description
Text	free text possibly with multiple lines	The text as entered in the notes fields. Note that the export is UTF-8 encoded and some characters that can be entered in to the web site may not appear as expected in the data export.
Unit	Site 1	The name of the Silhouette unit the patient is selected in. This is a special patient note field that is used in the standard <b>Details</b> patient notes and no where else.

Note fields that are set as not visible are still shown in the data export.

Note fields that are set as not active are not shown in the data export.

## Wound State Notes

The wound state columns include all the notes defined for capture with wound state observations. The column names can be set in the notes configuration.

These columns exist in wound exports and wound assessment exports. They do not exist in patient assessment exports.

The data types for the wound state notes fields are described within the [Patient Notes](#) section.

## Assessment Notes

The assessment notes columns include all the notes defined within the assessment type being exported. The column names can be set in the notes configuration.

The data types for the assessment notes fields are described within the [Patient Notes](#) section.

The assessment notes can also have image capture fields included. The following table shows the additional information included for an image capture field.

<b>Data Type</b>	<b>Column Name (appended to the Image Capture field name)</b>	<b>Description</b>
Image Capture	Image Count	The number of images assigned to the image capture field.

Data Type	Column Name (appended to the Image Capture field name)	Description
	Image with Outline Count	The number of images with wound outlines drawn. If an image has been tagged as having zero measurements then the outline count will be 0 for that image, but there will still be measurements reported (e.g. Area cm <sup>2</sup> = 0).

Data Type	Column Name (appended to the Image Capture field name)	Description
	Wound Fragment Count	The number of independent wound outlines drawn.

Data Type	Column Name (appended to the Image Capture field name)	Description
	Area cm2	The total area measurement for the image capture field. An empty value means there is no area measurement calculated for this assessment.

Data Type	Column Name (appended to the Image Capture field name)	Description
	Perimeter mm	The total perimeter measurement for the image capture field. An empty value means there is no perimeter measurement calculated for this assessment.

<b>Data Type</b>	<b>Column Name (appended to the Image Capture field name)</b>	<b>Description</b>
	Island Count	The number of wound islands drawn.



Data Type	Column Name (appended to the Image Capture field name)	Description
	Island Area cm2	<p>The total area for all the wound islands drawn.</p> <p>An empty value means there is no area measurement calculated for this assessment. If there is an area measurement and the island count is 0 then the Island Area will be 0.</p>

<b>Data Type</b>	<b>Column Name (appended to the Image Capture field name)</b>	<b>Description</b>
	Island Perimeter mm	The total perimeter for all the wound islands drawn. An empty value means there is no perimeter measurement calculated for this assessment.

Data Type	Column Name (appended to the Image Capture field name)	Description
	Length mm	The calculated wound length. An empty value can mean that there is no wound outline or that there are more than one wound outlines.

Data Type	Column Name (appended to the Image Capture field name)	Description
	Width mm	The calculated wound width. An empty value can mean that there is no wound outline or that there are more than one wound outlines.

Data Type	Column Name (appended to the Image Capture field name)	Description
	Max Depth mm	The maximum depth for the wound. An empty value can mean that there is no wound outline or that there are more than one wound outlines.

Data Type	Column Name (appended to the Image Capture field name)	Description
	Mean Depth mm	The mean depth for the wound. An empty value can mean that there is no wound outline or that there are more than one wound outlines.
	Volume cm3	The volume of the wound. An empty value can mean that there is no wound outline or that there are more than one wound outlines.
	Ruler Count	The number of rulers drawn on the images.
	Ruler Length mm	If there is a single ruler then this column contains the length of that ruler. If there are two (2) or more rulers then this column remains blank.
	Is Baseline Area Measurement	True or False. True, if this assessment is the baseline area measurement for this wound. False, if this assessment is not the baseline area measurement for this wound.
	Baseline Area Measurement Date	The date and time of the wounds baseline measurement assessment. This will be the same as the assessment date if Is Baseline Area Measurement column = True. This column is useful to calculate the days since baseline, giving context to the Area Reduction column.
	Baseline Area Timezone	The time zone name from the IANA Time Zone Database associated to the Baseline Area Measurement Date column.
	Area Reduction	The area reduction calculated for the assessment as a percentage to 1 dp. A blank value can mean that the area baseline measurement is after this assessment, there is no area baseline measurement for the wound or that there is no area measurement for this assessment.

Measurements will be omitted if there are no wound outlines. Measurements for some fields (e.g. Max Depth) may be omitted because the way the assessment is made or the capture device used doesn't support depth being calculated.

The measurement units used for the measurement columns is set by Silhouette organizational settings.

The number of decimal points included the data export is set by Silhouette organizational settings. The measurements can be exported as they appear in the Silhouette UI or set to a output as follows.

- Output to the nearest  $1/10^{\text{th}}$  of a mm for linear measurements.
- Output to the nearest  $1/10^{\text{th}}$  of a  $\text{mm}^2$  for area measurements.
- Output to the nearest  $1/10^{\text{th}}$  of a  $\text{mm}^3$  for volume measurements.

## Appendix G: Regular Expressions

Regular Expressions are patterns used to match character combinations in strings, for example a phone number or email address can be checked against a Regular Expression pattern.

Regular Expressions can be used in Silhouette to validate text field note entries. Users will not be able to enter values which do not conform to the specified Regular Expression pattern.

Regular Expressions use a definition language where characters have special meaning. There are many special characters, the ones used in the examples that follow are:

- Square brackets [], to specify the range of characters that are allowed.
- Curly brackets {}, to specify the number of times the previous pattern must match.
- Question mark ?, to specify the previous pattern must match 0 or 1 times.
- Carat ^, to specify the match must occur at the beginning of the string.
- Dollar sign \$, to specify the match must occur at the end of the string.
- Use of both ^ and \$ specifies that the whole input string must match the pattern.

### Patient Identifier Examples for Silhouette

#### Example A

A 5 digit patient number would be written as:

- `^[0-9]{5}$`
- Values satisfying this regular expression include 12345 and 70319
- Values not satisfying this regular expression include A1234 and 123456

#### Example B

A 3 digit unit ID, a dash, then a 3 digit patient number would be written as:

- `^[0-9]{3}-[0-9]{3}$`
- Values satisfying this regular expression include 147-963 and 456-321

#### Example C

Two upper-case alphabetic character unit ID, then 4 digit patient number, optionally followed by a dash and free text would be written as:

- `^[A-Z]{2}[0-9]{4}-?`
- Values satisfying this regular expression include ZK1648 and VT7642-ABC

#### Example D

A three-digit unit ID, a dash, a patient number comprising 4, 5 or 6 numeric digits, and the last character being an upper-case A, B, or C to indicate three different study groups would be written as:



## 154 • Other examples

- $^{[0-9]{3}}-[0-9]{4,6}[ABC]{1}\$$
- Values satisfying this regular expression include 010-01934A and 110-50012C

Through the simple use of regular expressions you can control the accuracy of information entered into a system and hence improve reliability and reduce errors.

Further reading and an interactive tutorial can be found here: <http://regexone.com/>

## Other examples

- International phone numbers should begin with a plus “+” character – e.g. +64 for New Zealand.
- An email address should contain only one “@” character
- A bank account number should begin with a two-digit bank identification number
- A credit card number comprises four groups of four digits
- A financial amount can comprise numeric digits, decimal point, commas, and the dollar sign e.g. \$41,031.64
- A patient name comprising first name, optional middle name, and surname.

Using Regular Expressions the following types of structures can be specified:

- A character from a group of characters, e.g.:
  - A lower-case alphabetic character [a-z]
  - An upper-or-lower case alphabetic character [a-zA-Z]
  - A numeric digit [0-9]
  - Alphanumeric characters comprising lower-case alphabetic or numeric digits [0-9a-z]
  - Commonly occurring punctuation characters such as dash “-”, comma “,”, period “.”, brackets “[”, and braces “{”, etc.
- A character can occur a fixed number of times, e.g.:  
Three characters which can be either a, b or c would be written as: [abc]{3}
- A single optional character is indicated by the question mark “?”, e.g.:  
An optional uppercase alphabetic character would be written as: [A-Z]?
- 1 upper-case alphabetic or 2 numeric digits could be required using the special or operator “|”:  
such as: [A-Z]|[0-9]{2}

Some real-world examples include:

- A credit card number - four groups of four digits separated by a dash:  
 $^{[0-9]{4}}-[0-9]{4}-[0-9]{4}-[0-9]{4}\$$
- A New Zealand national phone number - a two digit area code in brackets, followed by three digits, then a dash, then four digits:

`^\(0[1-9]\)[0-9]{3}-[0-9]{4}$`

## Things to Note

- The special treatment of the “(“ and “)” characters –these have special meaning within Regular Expression language so when they need to be used as normal characters this needs to be indicated. Preceding special characters with the “\” (“slash”) character tells the computer to treat the character as regular text - this is referred to as “escaping” a character. Other characters that may need escaping include “[“, “]”, even the slash itself requires escaping using a slash. “\”.
- The dash “-“ character generally doesn’t require escaping, although it does have special meaning when used to designate a character range within the square brackets. If a dash is used outside a character range statement then it will be interpreted as a normal character.
- If any part of the input matches the Regular Expression then the validation passes. If you wish to match the whole entry field then it is important to use the beginning of string “^” and end of string “\$” anchors.
- Regular Expressions can become very complex and testing them carefully to ensure they both accept and reject the correct input is important. It is also recommended to test the regular expressions on all applications used for data entry (i.e. SilhouetteCentral, SilhouetteConnect and SilhouetteLite+).

## Appendix H: Conditional Expression Syntax

Conditional expressions are used in a number of different features within Silhouette, including validation expressions, visibility expressions and triggers for emails. Conditional expressions should always be written as a boolean expression, evaluating as either true or false.

It is recommended to test conditional expressions on all target applications to ensure they provide consistent outcomes, e.g. test a visibility expression on SilhouetteCentral Web App and SilhouetteLite+ iOS App.

Conditional expressions can refer to any notes item that has been assigned a variable name. Variable name references are case sensitive.

As well as referring to variables, conditional expressions can contain constant values. Numbers must be written in decimal notation and text must be enclosed in single quotes, and boolean values are true or false e.g.

```
braden_score > 5
temperature <= 32.75
approval_status == 'undecided'
wound_state_recurring == true
```

As demonstrated in the previous sample expressions, it is possible to compare two or more values in an expression. The following logical operators are available.

Operator	Description	Example Expression
<=	Less than or equal to	height <= 150
<	Less than	height < 145
>=	Greater than or equal to	weight >= 275
>	Greater than	temperature > 35
==	Equal to	smoking_history == 'never smoked'
!=	Not equal to	admission_status != 'admitted'
!	Negation	!edema_present
&&	And	impaired_sensation_left && impaired_sensation_right
	Or	palliative_care    edema_present

Simple calculations can also be performed using the following mathematical operators

Operator	Description	Example Expression
+	Addition	left_area + right_area > 25
-	Subtraction	Initial - final > 14
*	Multiplication	length * width == 45
/	Division	volume / depth == area
%	Modulo	x % 5 == 1

There are also a number of functions available for use that can perform specialist operations:

Function	Description	Example Expressions
HasNoValue(x)	Returns true if variable 'x' does not contain a value. This is a convenience instead of having to write !HasValue(x)	HasNoValue(admission_status)
HasValue(x)	Returns true if variable 'x' contains a value. In other words it will return true if the user has recorded a value in the notes items within Silhouette.  NOTE: The single argument to HasValue must be a name of a variable.	HasValue(admission_status)
IsNull(x, y)	Returns the value of variable 'x' if the user has recorded a value in the notes field within Silhouette, otherwise returns the value 'y'.  NOTE: The first argument to IsNull must be the name of a variable.	IsNull(wound_pain, 0) > 5
ListContains(x, y)	Returns true if the multi-select list variable 'x' contains item 'y'.  NOTE: The first argument to ListContains must be the name of a variable.	ListContains(contributing_factors, 'Shearing')
ListLength(x)	Returns the number of items selected in a multi-select list variable 'x'.  NOTE: The single argument to ListLength must be the name of a variable.	ListLength(contributing_factors) > 2
ParseInt(x)	Converts a string into an integer value. Causes an error if the argument is not correctly formatted.  This function is useful if comparing the value of a selected lookup item. The values are returned as strings and the ParseInt function must be used to convert them to integers.	ParseInt(variable_name) <= 5

Expressions are evaluated with standard precedence of operators. You can place sub-expressions in brackets, or parenthesis to alter the precedence if required.

## Appendix I: Template Macros

Template macros allow a template string to include details retrieved from the data dynamically at run-time, e.g. a report filename can include data from the patient or assessment.

A macro is indicated by a set of curly braces in the general form *{Source,Path,Empty}*, where:

- *Source* describes the entity to retrieve the value from.
- *Path* defines exactly which value from the *Source* is desired to.
- *Empty* (optional) is used as a value to return if the macro value obtained is NULL or an empty string. If an *Empty* parameter is not provided then an empty string is returned.

The source and path macros available depend upon the context in which the format string will be utilized, e.g. a *wound* source makes sense in a filename template for a wound assessment but not for a patient assessment.

The *Source* and *Path* are case insensitive.

To be identified as a macro within a template string, the macro must have:

- Opening and closing curly braces.
- A *Source* value without leading or trailing space characters.
- A comma (,).
- A *Path* value without a leading space character.

Text in the string that does not meet the above pattern is treated as literal text, e.g. `{}` is treated as literal `{}` or `{source , path}` is treated as literal `{source , path}`.

### Dates

The date and time formats used by Silhouette are ISO 8601 formats, specifically:

- 'yyyy-MM-ddTHH:mm:ssZ' for date and time values.
- 'yyyy-MM-dd' for date values.

### Assessment Integration Filename Templates

The following macros are available for the assessment integration filename templates.

Source	Description				
System	Information associated with the SilhouetteCentral environment that is processing the request. <table border="1"> <thead> <tr> <th>Path</th> <th>Description</th> </tr> </thead> <tbody> <tr> <td>Date</td> <td>The current date and time of the server processing the request.</td> </tr> </tbody> </table>	Path	Description	Date	The current date and time of the server processing the request.
Path	Description				
Date	The current date and time of the server processing the request.				
Assessment	Information associated with the assessment related to the current macro context. <table border="1"> <thead> <tr> <th>Path</th> <th>Description</th> </tr> </thead> <tbody> <tr> <td>Date</td> <td>The date and time the assessment was originally created.</td> </tr> </tbody> </table>	Path	Description	Date	The date and time the assessment was originally created.
Path	Description				
Date	The date and time the assessment was originally created.				

Source	Description												
Wound	<p>Information associated with the wound related to the current macro context.</p> <table border="1"> <thead> <tr> <th>Path</th> <th>Description</th> </tr> </thead> <tbody> <tr> <td>Label</td> <td>The wound index / label e.g. "A" or "1".</td> </tr> <tr> <td>AnatomicalSite</td> <td> <p>A description of the anatomical site the wound is associated with.</p> <p>The Anatomical Site description as it shows in the UI and the Anatomical Site code configured in Silhouette are both made available to the integration engine.</p> </td> </tr> </tbody> </table>	Path	Description	Label	The wound index / label e.g. "A" or "1".	AnatomicalSite	<p>A description of the anatomical site the wound is associated with.</p> <p>The Anatomical Site description as it shows in the UI and the Anatomical Site code configured in Silhouette are both made available to the integration engine.</p>						
Path	Description												
Label	The wound index / label e.g. "A" or "1".												
AnatomicalSite	<p>A description of the anatomical site the wound is associated with.</p> <p>The Anatomical Site description as it shows in the UI and the Anatomical Site code configured in Silhouette are both made available to the integration engine.</p>												
Order	<p>Information associated with an order related to the current macro context.</p> <p>Typically the macro context is related to an order through the assessment. There can be zero, one or many orders linked to an assessment. When there are no orders linked then the macros return empty strings and when there are many orders linked, the macros return data based on the last order linked.</p> <table border="1"> <thead> <tr> <th>Path</th> <th>Description</th> </tr> </thead> <tbody> <tr> <td>orderid</td> <td>The order id field.</td> </tr> <tr> <td>status</td> <td>The status of the order, either <i>Active</i> or <i>Completed</i>.</td> </tr> <tr> <td>scheduleddate</td> <td>The scheduled date and time of the order in UTC and ISO 8601 compliant format, e.g. 2016-03-10T19_43_00Z.</td> </tr> <tr> <td>description</td> <td>The description of the order in Silhouette.</td> </tr> <tr> <td>maxassessments</td> <td>The maximum assessments configured for the order within Silhouette.</td> </tr> </tbody> </table> <p>All other order and encounter notes are accessible via the <i>Notes</i> source.</p>	Path	Description	orderid	The order id field.	status	The status of the order, either <i>Active</i> or <i>Completed</i> .	scheduleddate	The scheduled date and time of the order in UTC and ISO 8601 compliant format, e.g. 2016-03-10T19_43_00Z.	description	The description of the order in Silhouette.	maxassessments	The maximum assessments configured for the order within Silhouette.
Path	Description												
orderid	The order id field.												
status	The status of the order, either <i>Active</i> or <i>Completed</i> .												
scheduleddate	The scheduled date and time of the order in UTC and ISO 8601 compliant format, e.g. 2016-03-10T19_43_00Z.												
description	The description of the order in Silhouette.												
maxassessments	The maximum assessments configured for the order within Silhouette.												
Notes	<p>Provides access to all patient information and assessment notes recorded for the patient and assessment currently being processed.</p> <p>'Path' should be of a valid variable associated with a notes field and the current value for that notes field will be returned. The variables for the default set of notes are listed in <a href="#">Appendix C: Wound State Definitions</a> and <a href="#">Appendix D: Notes Definitions</a>.</p> <p>If a Single Select List note variable is requested, both the lookup text and the lookup code are made available to the integration engine.</p> <p>If an unknown variable name is requested an empty string will be returned.</p>												

## Examples:

- {notes,details\_patient\_id} returns the Patient Id.
- {wound,label} returns the wound label, 'A'.
- {assessment,date} returns the date of the assessment, e.g. 2000-01-03T19:30:22+5.
- {notes,details\_unit} returns the current unit for the patient.

## 160 • Assessment Integration Filename Templates

- {Wound,AnatomicalSite} returns the anatomical site as seen in Silhouette, including the auxiliary text.
- {Notes,details\_date\_of\_birth} returns the patients date of birth, e.g. 1988-01-14.
- {Notes,details\_is\_female} returns the patients gender, e.g. Male.
- {System,Date} returns the current date and time on the SilhouetteCentral server, e.g. 2019-10-19T07:30:02+13.

The macros can also be used to configure:

- Identifiable file names when exporting assessments and images via the application UI.
- Password reset emails.



This additional configuration is only accessible by ARANZ support and the macros differ slightly to those listed in this appendix. Refer to Silhouette v3 documentation for macros applicable to the legacy configuration.

## Appendix J: Email Templates

The email template uses the ASP.NET Razor View Engine to form an HTML email and can access the data model of Silhouette to include data from the assessment into the body of the email. The email template files are provided as *.cshhtml* files.

These files generally start with a @model statement which tells Silhouette which data model to load.

Contact your ARANZ Medical representative for support in creating custom Email templates.

### Silhouette Assessment Emails

The data model used in the Assessment Email template is Silhouette.Email.Template.Models.Assessment. This data model is complex and comprehensive, providing access to:

- Assessment data
- Wound data
- Patient data
- Order data
- Encounter data

The exact model structure is not documented here. Contact your ARANZ Medical representative for support in creating custom Email templates.



Consider patient information data privacy when creating email templates to be sent from Silhouette. If any personal data is included in the email template then you need to consider any data privacy issues, including processing by email sending providers and email recipient systems.

### Silhouette Welcome Emails

The data model used in the Welcome Email templates is Silhouette.Email.Template.Models.User. The table below describes the contents of the model which can be used in the Welcome Email templates.

Model Element	Description
FirstName	The first name of the user.
LastName	The last name of the user.
EmailAddress	The Email address of the user.
UserName	The Silhouette user name allocated to the user.
Silhouette.SilhouetteCentralUrl	The base URL of SilhouetteCentral. Use this to provides a link in the Email to the SilhouetteCentral instance.



Model Element	Description
Silhouette.SilhouetteConnectDownloadUrl	<p>Provides a URL to download the SilhouetteConnect installer for the instance of SilhouetteCentral generating the email.</p> <p>Use this to provide clinical users with a SilhouetteConnect download that is bootstrapped with the same licensing client code as SilhouetteCentral and the configuration to sync to the SilhouetteCentral instance.</p>
Silhouette.SilhouetteHelpUrl	Provides a URL to the Silhouette help files hosted by ARANZ Medical.